

# G-MD

# Thrust Bearings

TILTING PAD THRUST BEARING SERIES

S14x68

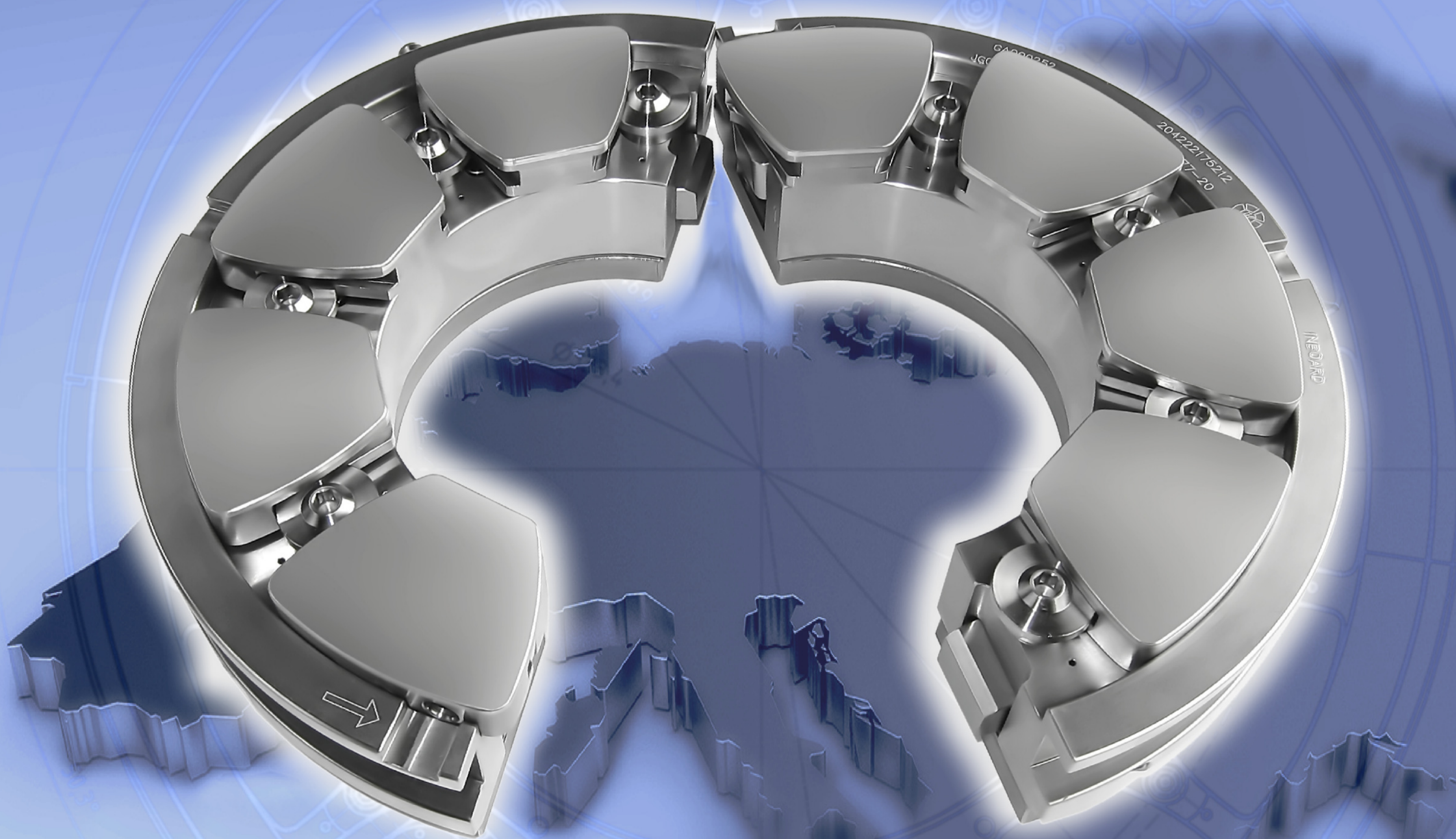

Modular Design  
Series 6, 8, 11, 14  
Self-Equalized | Non-Equalized  
Offset & Center Pivot  
Directed & Flooded Lubrication

# G-MD THRUST BEARING

Kingsbury GmbH's G-MD Tilting Pad Thrust Bearing is a universal bearing solution that guarantees the highest design flexibility. The variety of options shown in this catalog allows its adaptation to the widest range of specifications and toughest applications. Individual bearing designs with pad counts from 5 to 28 or partly equipped base rings with fewer pads can be arranged.

For engineering assistance on OEM or aftermarket applications, contact our offices in Göttingen, Germany or Philadelphia, PA, USA. Please see the back cover of this catalog for contact details.

## TABLE OF CONTENTS

Introduction and General Description	3
Series 6	4
Series 8	6
Series 11	8
Series 14	10
Design Options and Description	12
Instrumentation	13
Installation	14
Product Code	14
Bearing Calculation	15

All content is ©2019 Kingsbury GmbH with exception of following photographs used with kind permission:

front page: R. Beneke, "IMG\_0611.JPG"  
Lionfive, Pixabay.com "3d-model-2901886"  
page two: Achim Scholty, Pixabay.com "Power-plant-3878137"

# INTRODUCTION

## INTRODUCTION AND GENERAL DESCRIPTION

Customer needs have always been the focus of all services and design solutions offered by Kingsbury. To better respond to present and future design requirements and alternatives, Kingsbury has further enhanced its product portfolio and developed the G-MD Standard in Germany.

The G-MD Standard can be used for uni- and bi-directional operation with flooded or directed lubrication and equalized or non-equalized designs. They are geometrically compatible with existing competitive products.

Further design options are available, such as temperature sensor locations, alternative materials, split or solid assemblies. Optional spacers and shim packs can be selected to individual customer requirements for rotor positioning and setting clearances.

All bearings share key design features. The pads have rounded corners and wide radii at the leading and trailing edges, which allow oil to freely flow through the inlet and outlet of the bearing regardless of the number of pads (5 to 28). The pads are retained by a universal retaining screw that also serves as a spray nozzle in case of directed lubrication.

The bearing performance benefits from a spherical pad support commonly used on Kingsbury bearings. The spherical support allows the pad to adjust to possible imperfections in the collar or housing due to manufacturing, mechanical deflection or thermal expansion. Partly equipped base rings or special instrumentation, such as load cells for thrust measurement, can also be considered for specific instances.

The use of interchangeable pads for the various G-MD series enables us to stock many sizes and reduce the lead-time for both assemblies and spare parts.

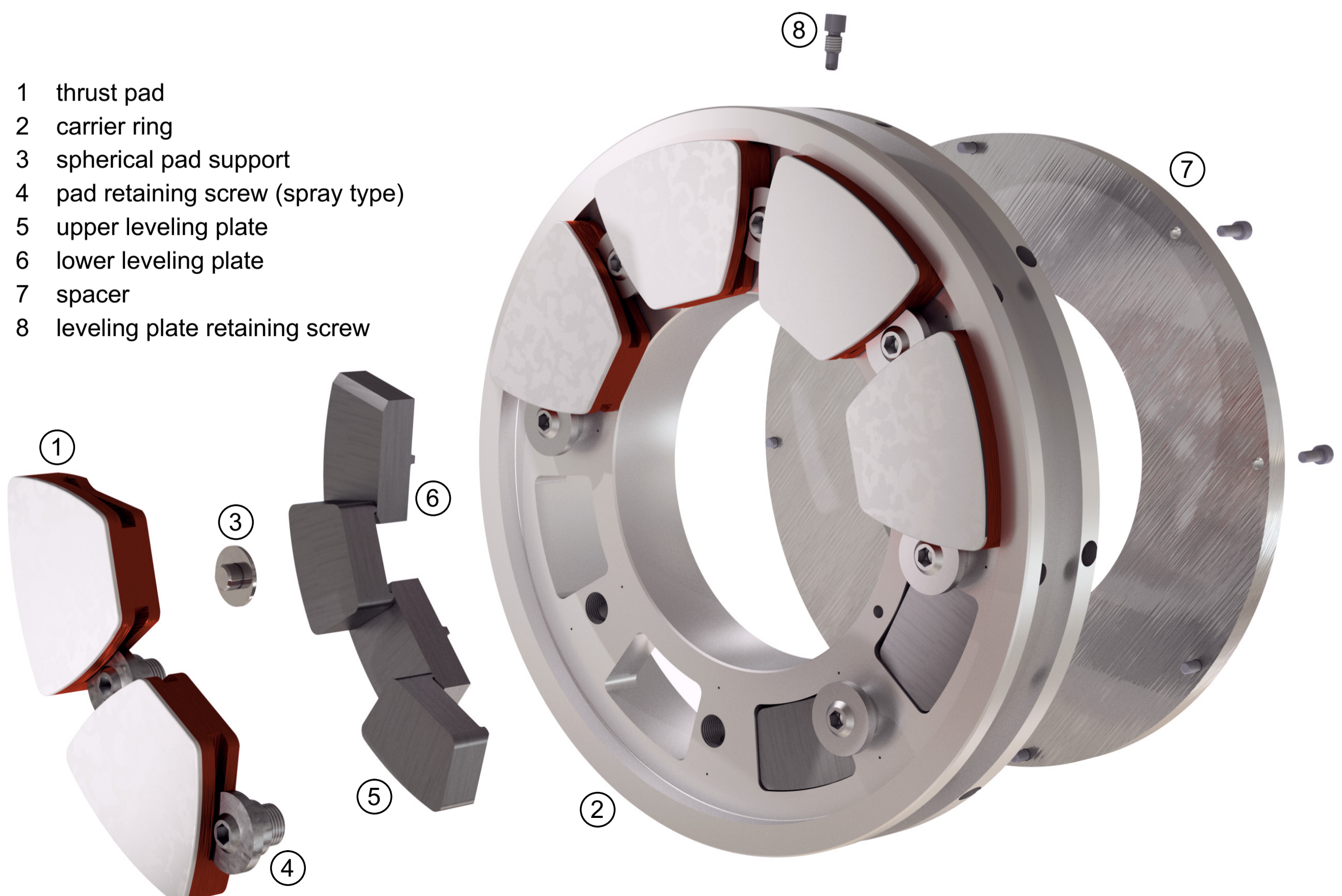

## Self-Equalized

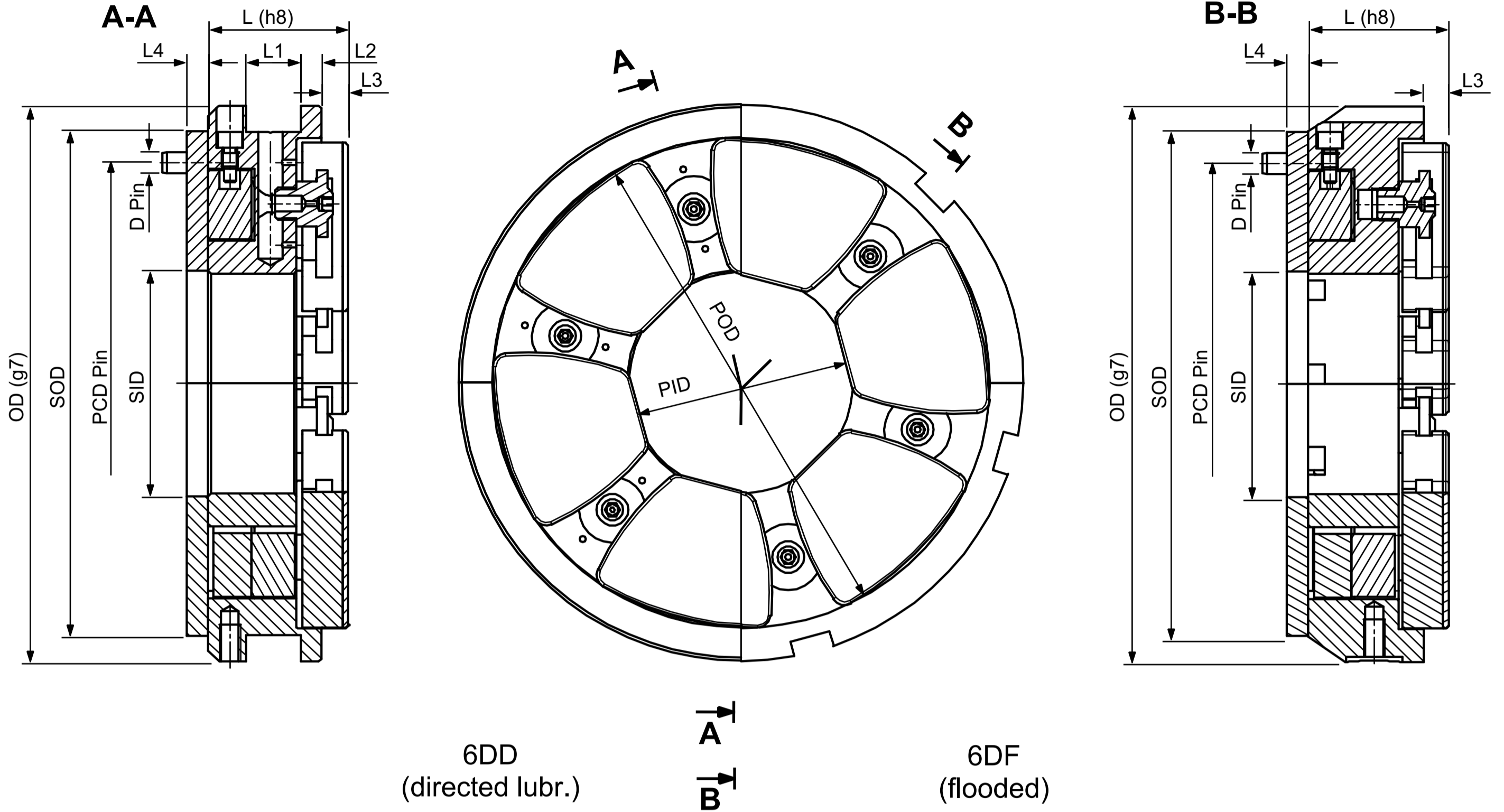

6DD  
(directed lubr.)

6DF  
(flooded)

Size	PID	OD	L	POD	L1	L2	L3	L4	SID	SOD	D	PCD
23	37.6	98.41	23.5	84.5	8.0	4.1	4.5	5	40	90	6	81
26	39.0	107.91	25.5	91.8	9.0	4.5	4.7	5	42	99	6	89
28	42.9	115.85	28.0	99.9	10.0	5.2	5.0	5	45	105	6	99
31	47.3	126.96	30.0	110.4	11.0	4.5	5.3	6	51	116	6	108
34	51.0	139.66	34.0	120.2	13.0	5.3	5.8	6	54	127	8	118
37	55.4	147.60	36.0	130.7	14.0	5.4	6.4	6	59	135	8	126
40	60.5	165.06	41.0	142.0	16.0	7.2	6.6	6	64	153	8	140
44	65.4	179.35	43.0	154.9	17.0	6.3	7.2	6	70	162	10	153
48	71.7	193.63	46.0	169.4	18.0	7.5	7.8	8	76	176	10	165
52	78.8	209.50	52.0	184.8	20.5	8.3	9.3	8	85	190	10	181
57	86.4	228.55	56.0	202.5	22.0	9.3	10.0	8	93	209	12	198
62	93.9	247.60	61.0	220.4	23.0	11.5	10.5	8	100	228	12	215
68	101.2	266.64	65.0	240.0	26.0	10.5	11.0	8	108	247	12	233
74	110.7	292.04	68.0	261.9	27.5	10.4	12.1	10	117	270	12	255
81	120.7	317.44	76.0	286.2	31.0	12.6	13.2	10	127	295	16	280
89	129.0	342.84	80.0	310.8	32.0	14.0	14.3	10	135	320	16	305
97	140.9	371.42	88.0	339.2	35.0	16.9	14.9	10	147	347	16	331
105	152.9	406.33	95.0	367.7	38.0	16.3	17.5	10	159	382	20	360
115	171.0	441.31	102.0	406.5	42.0	16.5	19.0	12	177	417	20	394
125	181.7	482.58	110.0	437.6	45.0	18.2	21.1	12	188	458	20	427

For inquiries and orders, please refer to our product code on page 14

**Non-Equalized**

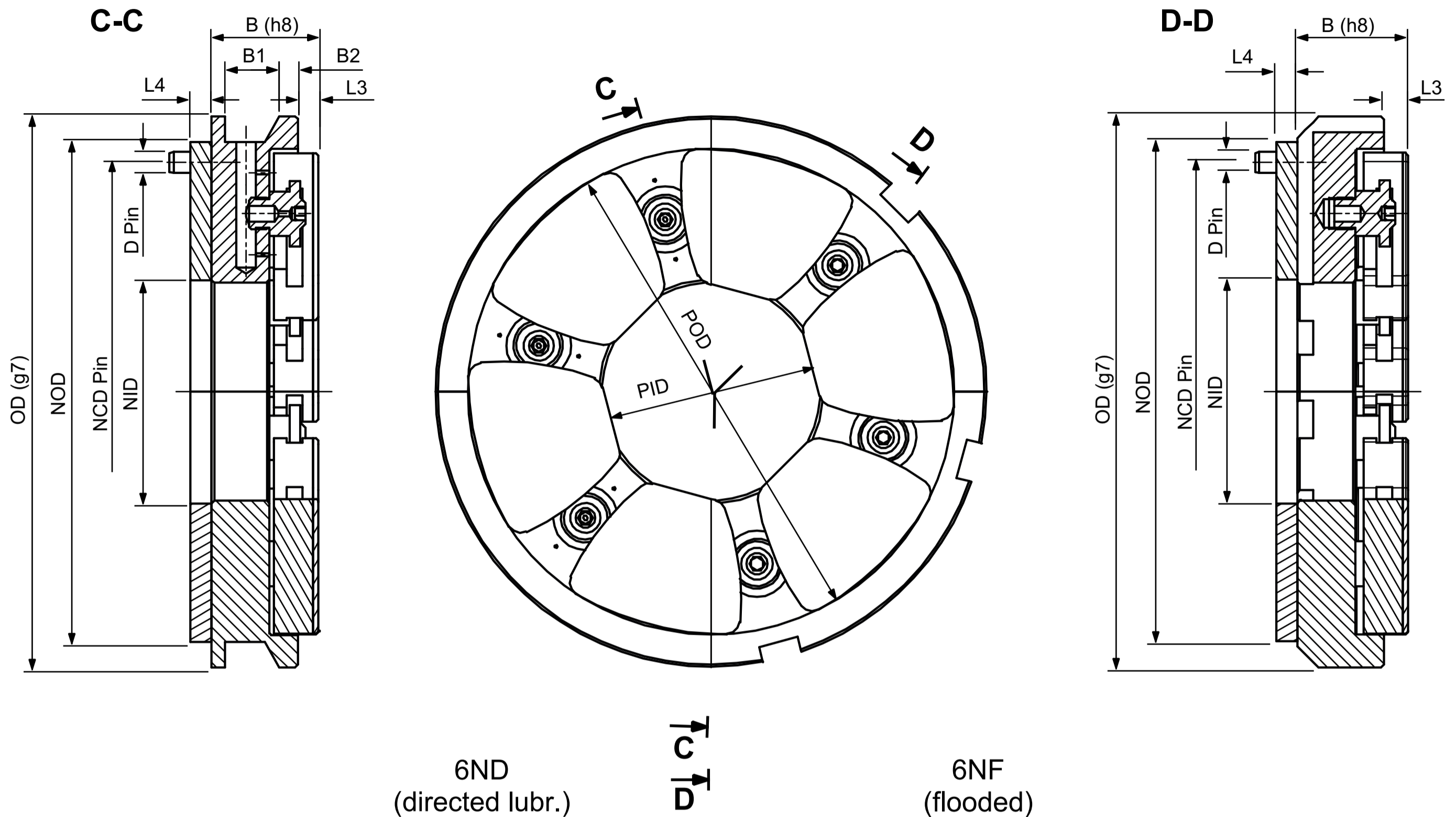

Size	PID	OD	B	POD	B1	B2	L3	L4	NID	NOD	D	NCD
23	37.6	98.41	21.26	84.5	8.0	4.1	4.5	5	44	88	6	66
26	39.0	107.91	23.95	91.8	9.0	4.5	4.7	5	46	97	6	72
28	42.9	115.85	25.54	99.9	10.0	5.2	5.0	5	49	102	6	76
31	47.3	126.96	27.12	110.4	11.0	4.5	5.3	6	56	113	6	85
34	51.0	139.66	28.71	120.2	13.0	5.3	5.8	6	59	123	8	91
37	55.4	147.60	30.30	130.7	14.0	5.4	6.4	6	64	131	8	98
40	60.5	165.06	31.89	142.0	15.0	5.8	6.6	6	70	149	8	110
44	65.4	179.35	35.06	154.9	17.0	6.3	7.2	6	76	157	10	117
48	71.7	193.63	38.94	169.4	18.0	7.5	7.8	8	82	171	10	127
52	78.8	209.50	42.11	184.8	20.0	8.3	9.3	8	92	185	10	139
57	86.4	228.55	45.29	202.5	22.0	9.3	10.0	8	100	203	12	152
62	93.9	247.60	48.46	220.4	23.0	11.5	10.5	8	107	222	12	165
68	101.2	266.64	51.64	240.0	26.0	10.5	11.0	8	116	241	12	179
74	110.7	292.04	54.81	261.9	27.5	10.4	12.1	10	125	262	12	194
81	120.7	317.44	61.16	286.2	31.0	12.6	13.2	10	135	287	16	211
89	129.0	342.84	64.34	310.8	32.0	14.0	14.3	10	145	312	16	229
97	140.9	371.42	73.70	339.2	35.0	16.9	14.9	10	157	337	16	247
105	152.9	406.33	80.05	367.7	38.0	16.3	17.5	10	169	372	20	271
115	171.0	441.31	86.40	406.5	42.0	16.5	19.0	12	189	405	20	297
125	181.7	482.58	95.45	437.6	45.0	18.2	21.1	12	200	446	20	323

For pad surface, see table page 14

Self-Equalized

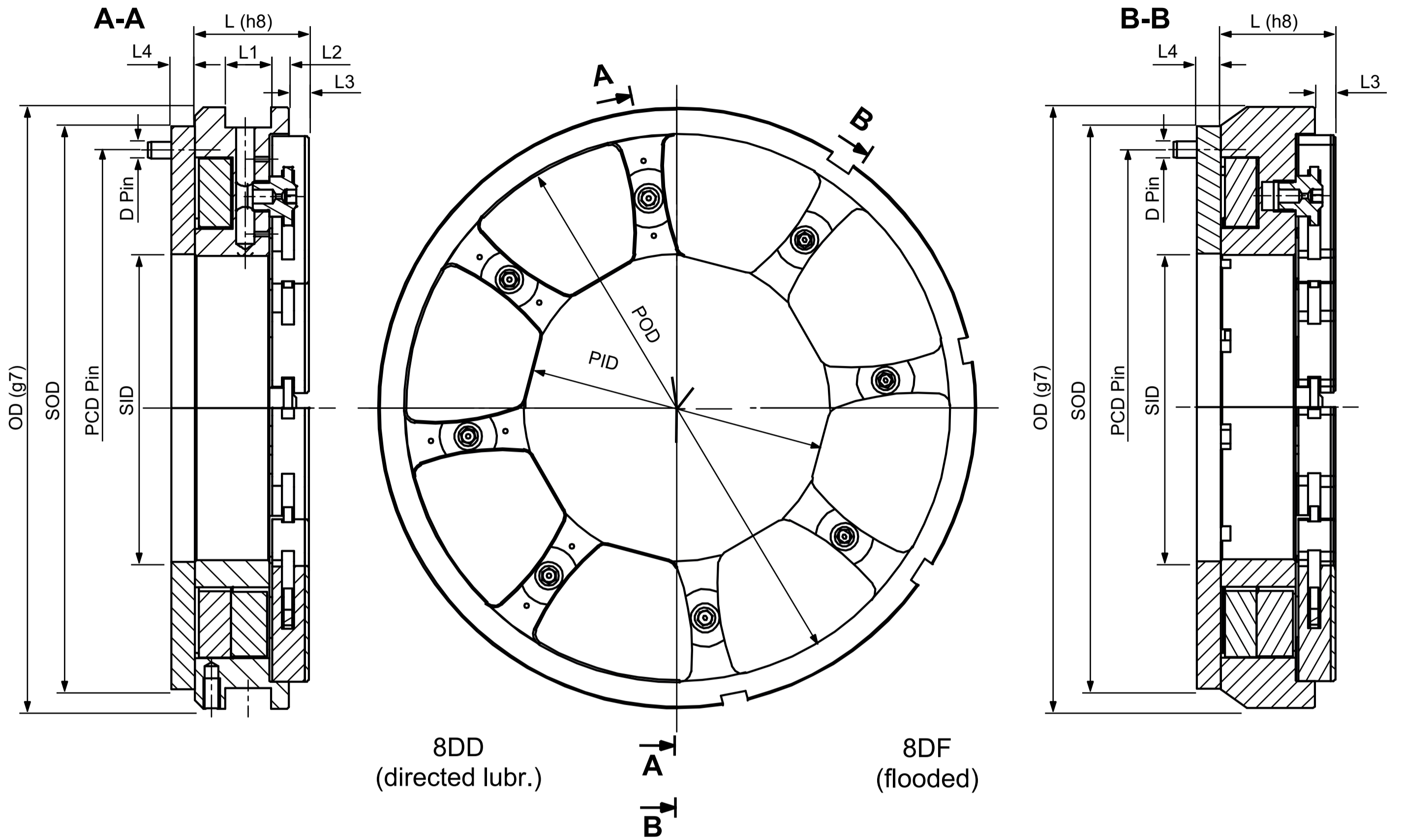

Size	PID	OD	L	POD	L1	L2	L3	L4	SID	SOD	D	PCD
23	59.0	120.65	23.5	105.0	8.0	4.1	4.5	5	62	112	6	103
26	62.0	130.17	25.5	114.0	9.0	4.5	4.7	5	65	122	6	111
28	68.0	139.69	28.0	124.0	10.0	5.2	5.0	5	71	129	6	123
31	75.0	152.39	30.0	137.0	11.0	4.5	5.3	6	79	142	6	135
34	81.0	168.27	34.0	149.0	13.0	5.3	5.8	6	84	156	8	148
37	88.0	180.95	36.0	162.0	14.0	5.4	6.4	6	92	168	8	159
40	96.0	196.84	41.0	176.0	16.0	7.2	6.6	6	100	184	8	174
44	104.0	215.89	43.0	192.0	17.0	6.3	7.2	6	109	198	10	191
48	114.0	234.94	46.0	210.0	18.0	7.5	7.8	8	119	217	10	207
52	125.0	253.98	52.0	229.0	20.5	8.3	9.3	8	132	234	10	226
57	137.0	279.38	56.0	251.0	22.0	9.3	10.0	8	144	260	12	249
62	149.0	301.61	61.0	273.0	23.0	11.5	10.5	8	155	282	12	269
68	161.0	323.83	65.0	297.0	26.0	10.5	11.0	8	168	304	12	292
74	176.0	355.58	68.0	324.0	27.5	10.4	12.1	10	183	333	12	320
81	192.0	384.16	76.0	354.0	31.0	12.6	13.2	10	199	362	16	349
89	206.0	415.93	80.0	384.0	32.0	14.0	14.3	10	213	393	16	380
97	225.0	454.03	88.0	419.0	35.0	16.9	14.9	10	232	430	16	414
105	244.0	495.30	95.0	454.0	38.0	16.3	17.5	10	251	471	20	450
115	272.0	539.75	102.0	502.0	42.0	16.5	19.0	12	278	515	20	494
125	290.0	584.20	110.0	540.0	45.0	18.2	21.1	12	297	560	20	532

For inquiries and orders, please refer to our product code on page 14

**Non-Equalized**

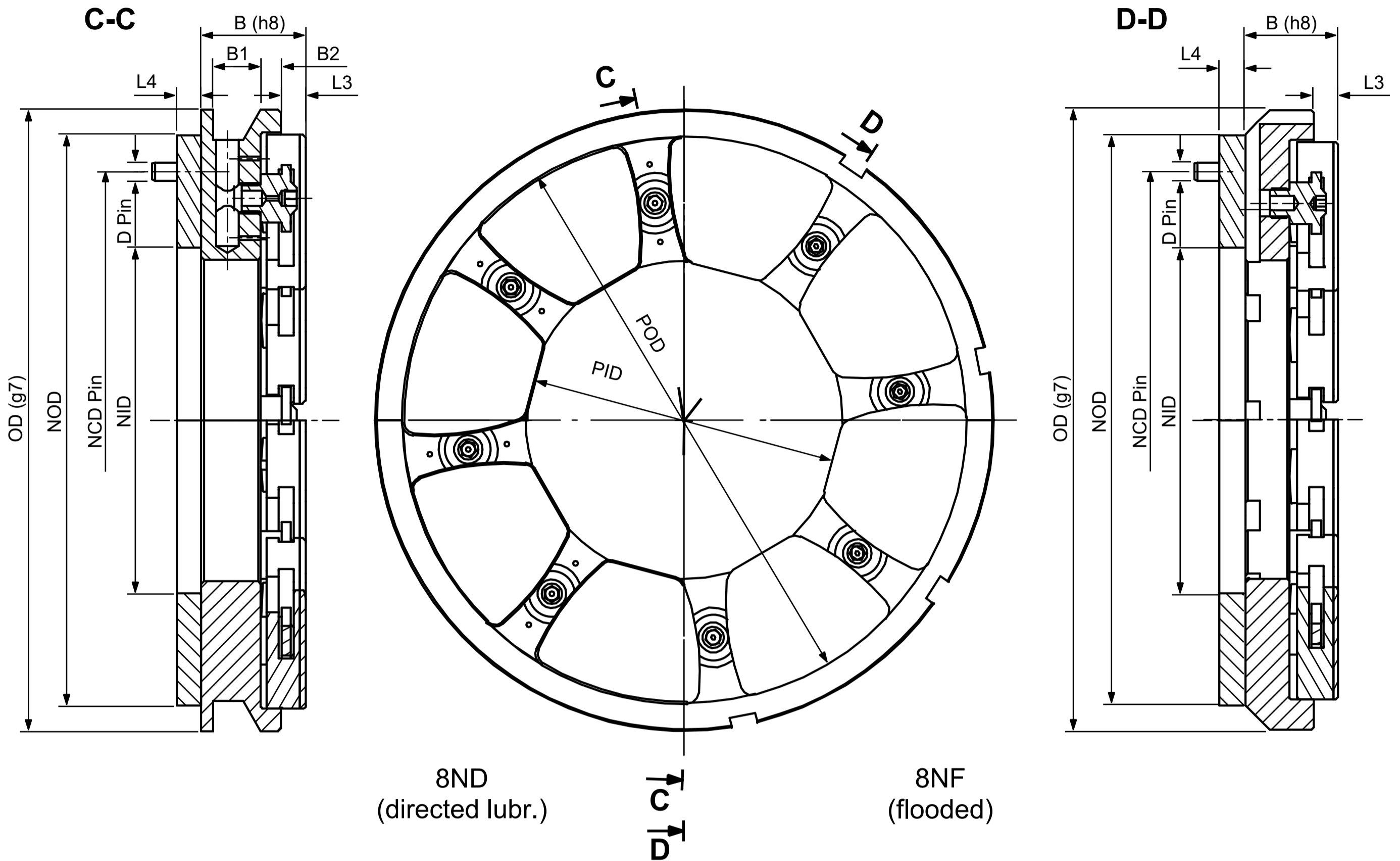

Size	PID	OD	B	POD	B1	B2	L3	L4	NID	NOD	D	NCD
23	59.0	120.65	21.26	105.0	8.0	4.1	4.5	5	66	110	6	88
26	62.0	130.17	23.95	114.0	9.0	4.5	4.7	5	69	120	6	95
28	68.0	139.69	25.54	124.0	10.0	5.2	5.0	5	75	126	6	101
31	75.0	152.39	27.12	137.0	11.0	4.5	5.3	6	84	139	6	112
34	81.0	168.27	28.71	149.0	13.0	5.3	5.8	6	89	152	8	121
37	88.0	180.95	30.30	162.0	14.0	5.4	6.4	6	97	164	8	131
40	96.0	196.84	31.89	176.0	15.0	5.8	6.6	6	106	180	8	143
44	104.0	215.89	35.06	192.0	17.0	6.3	7.2	6	115	193	10	154
48	114.0	234.94	38.94	210.0	18.0	7.5	7.8	8	125	212	10	169
52	125.0	253.98	42.11	229.0	20.0	8.3	9.3	8	139	229	10	184
57	137.0	279.38	45.29	251.0	22.0	9.3	10.0	8	151	254	12	203
62	149.0	301.61	48.46	273.0	23.0	11.5	10.5	8	162	276	12	219
68	161.0	323.83	51.64	297.0	26.0	10.5	11.0	8	176	298	12	237
74	176.0	355.58	54.81	324.0	27.5	10.4	12.1	10	191	325	12	258
81	192.0	384.16	61.16	354.0	31.0	12.6	13.2	10	207	354	16	281
89	206.0	415.93	64.34	384.0	32.0	14.0	14.3	10	223	385	16	304
97	225.0	454.03	73.70	419.0	35.0	16.9	14.9	10	242	420	16	331
105	244.0	495.30	80.05	454.0	38.0	16.3	17.5	10	261	461	20	361
115	272.0	539.75	86.40	502.0	42.0	16.5	19.0	12	290	503	20	397
125	290.0	584.20	95.45	540.0	45.0	18.2	21.1	12	309	548	20	429

For pad surface, see table page 14

## Self-Equalized

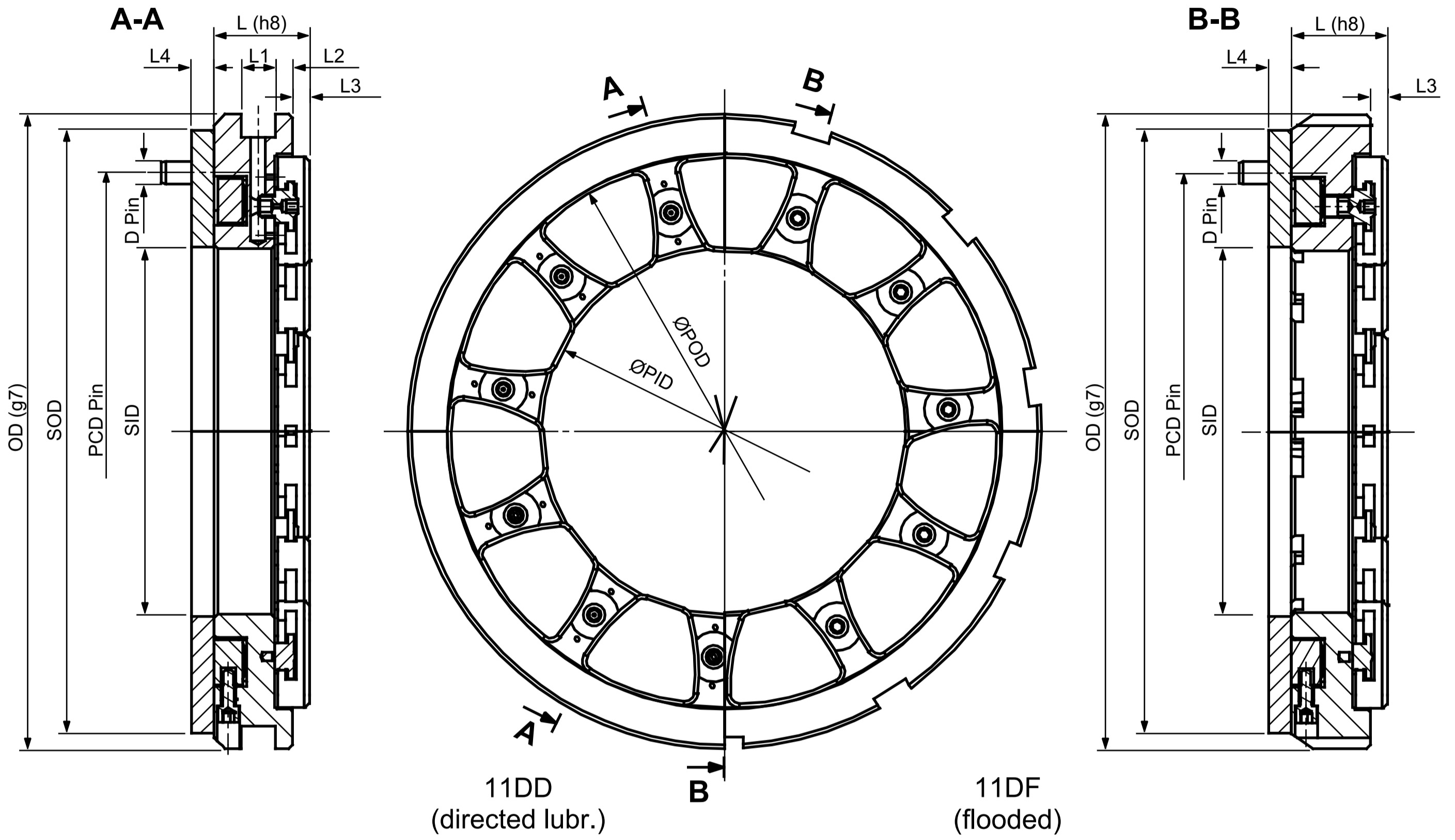

Size	PID	OD	L	POD	L1	L2	L3	L4	SID	SOD	D	PCD
23	90.1	152.40	23.5	136.1	8.0	4.1	4.5	5	93	144	6	134
26	95.4	168.27	25.5	147.4	9.0	4.5	4.7	5	98	160	6	147
28	104.4	180.97	28.0	160.4	10.0	5.2	5.0	5	107	170	6	161
31	115.2	196.84	30.0	177.2	11.0	4.5	5.3	6	119	186	6	177
34	124.6	212.72	34.0	192.6	13.0	5.3	5.8	6	128	200	8	192
37	135.4	234.94	36.0	209.4	14.0	5.4	6.4	6	139	222	8	209
40	147.6	253.98	41.0	227.6	16.0	7.2	6.6	6	151	241	8	227
44	160.2	279.38	43.0	248.2	17.0	6.3	7.2	6	165	262	10	250
48	175.5	301.61	46.0	271.5	18.0	7.5	7.8	8	180	284	10	271
52	192.2	323.83	52.0	296.2	20.5	8.3	9.3	8	199	304	10	295
57	210.6	355.58	56.0	324.6	22.0	9.3	10.0	8	217	336	12	324
62	229.1	384.16	61.0	353.1	23.0	11.5	10.5	8	236	365	12	350
68	247.9	415.91	65.0	383.9	26.0	10.5	11.0	8	254	396	12	381
74	270.9	454.01	68.0	418.9	27.5	10.4	12.1	10	277	431	12	416
81	295.6	495.28	76.0	457.6	31.0	12.6	13.2	10	302	473	16	456
89	317.9	539.75	80.0	495.9	32.0	14.0	14.3	10	324	517	16	497
97	347.2	584.20	88.0	541.2	35.0	16.9	14.9	10	354	560	16	540
105	376.4	641.35	95.0	586.4	38.0	16.3	17.5	10	383	617	20	588
115	418.8	692.15	102.0	648.8	42.0	16.5	19.0	12	425	668	20	643
125	447.5	755.65	110.0	697.5	45.0	18.2	21.1	12	454	731	20	696

For inquiries and orders, please refer to our product code on page 14

**Non-Equalized**

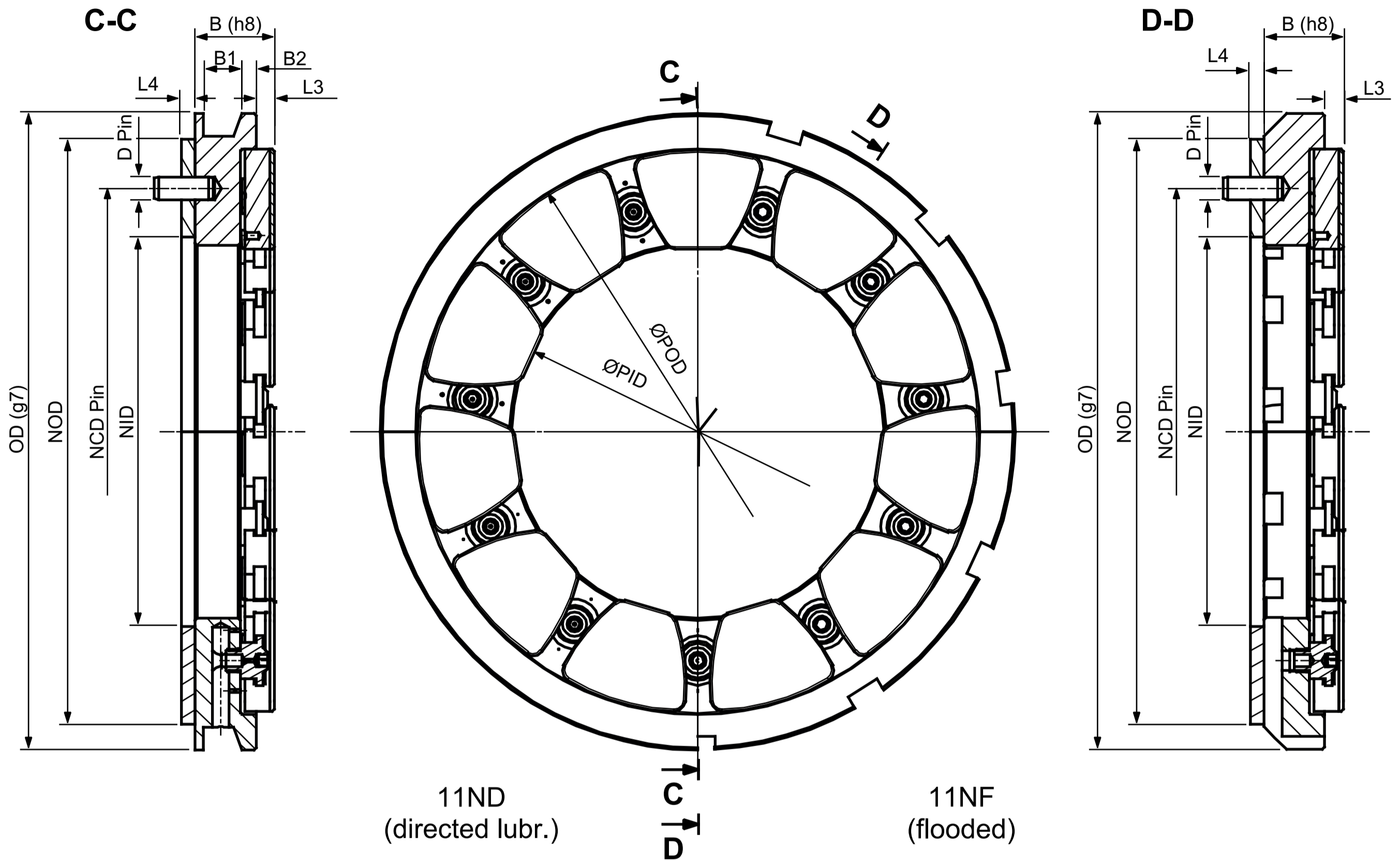

Size	PID	OD	B	POD	B1	B2	L3	L4	NID	NOD	D	NCD
23	90.1	152.40	21.26	136.1	8.0	4.1	4.5	5	97	142	6	120
26	95.4	168.27	23.95	147.4	9.0	4.5	4.7	5	102	158	6	130
28	104.4	180.97	25.54	160.4	10.0	5.2	5.0	5	111	167	6	139
31	115.2	196.84	27.12	177.2	11.0	4.5	5.3	6	124	183	6	154
34	124.6	212.72	28.71	192.6	13.0	5.3	5.8	6	133	196	8	165
37	135.4	234.94	30.30	209.4	14.0	5.4	6.4	6	144	218	8	181
40	147.6	253.98	31.89	227.6	15.0	5.8	6.6	6	157	237	8	197
44	160.2	279.38	35.06	248.2	17.0	6.3	7.2	6	171	257	10	214
48	175.5	301.61	38.94	271.5	18.0	7.5	7.8	8	186	279	10	233
52	192.2	323.83	42.11	296.2	20.0	8.3	9.3	8	206	299	10	253
57	210.6	355.58	45.29	324.6	22.0	9.3	10.0	8	224	330	12	277
62	229.1	384.16	48.46	353.1	23.0	11.5	10.5	8	243	359	12	301
68	247.9	415.91	51.64	383.9	26.0	10.5	11.0	8	262	390	12	326
74	270.9	454.01	54.81	418.9	27.5	10.4	12.1	10	285	423	12	354
81	295.6	495.28	61.16	457.6	31.0	12.6	13.2	10	310	465	16	388
89	317.9	539.75	64.34	495.9	32.0	14.0	14.3	10	334	509	16	422
97	347.2	584.20	73.70	541.2	35.0	16.9	14.9	10	364	550	16	457
105	376.4	641.35	80.05	586.4	38.0	16.3	17.5	10	393	607	20	500
115	418.8	692.15	86.40	648.8	42.0	16.5	19.0	12	437	656	20	547
125	447.5	755.65	95.45	697.5	45.0	18.2	21.1	12	466	719	20	593

For pad surface, see table page 14

## Self-Equalized

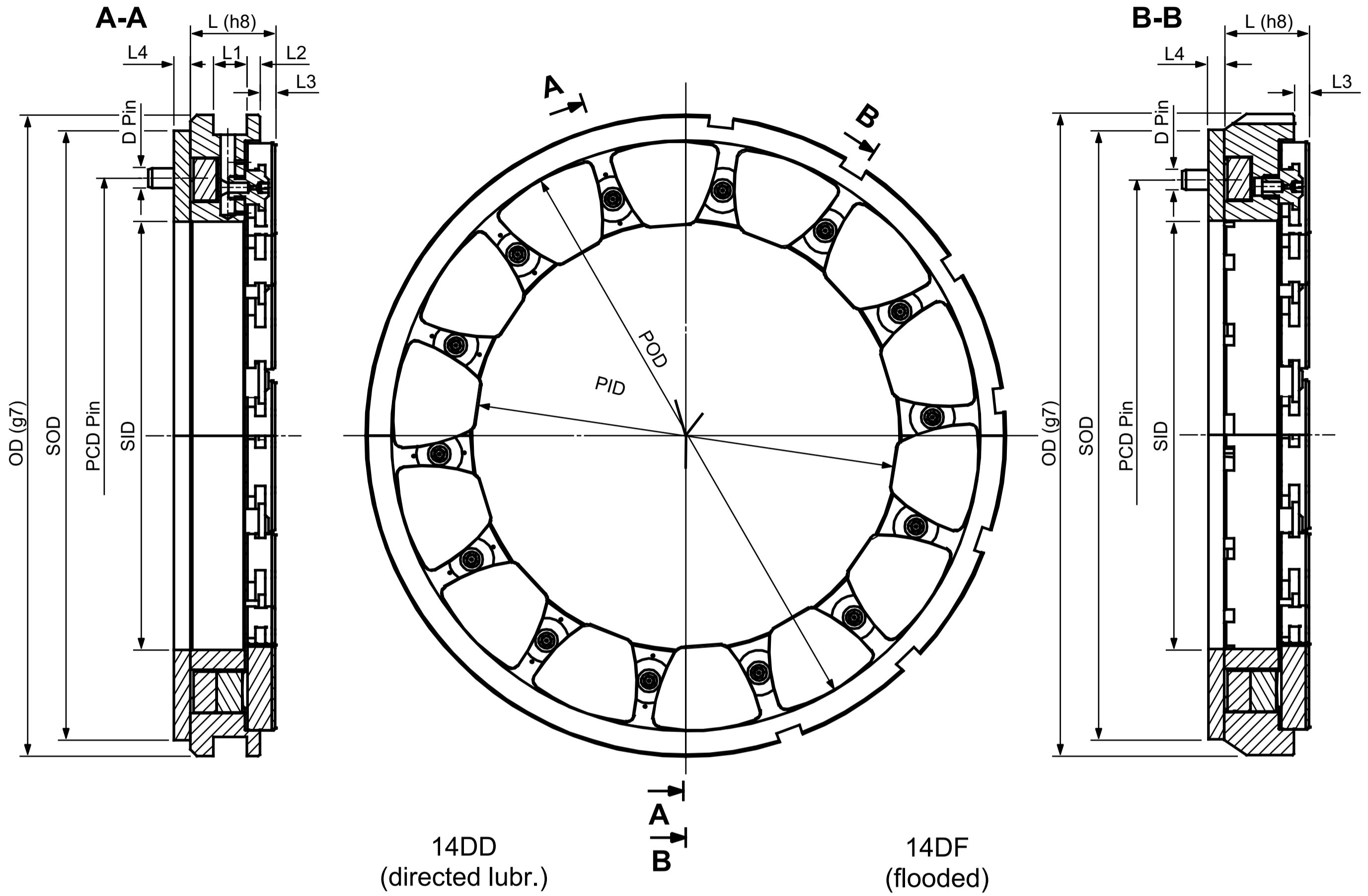

Size	PID	OD	L	POD	L1	L2	L3	L4	SID	SOD	D	PCD
23	120.7	184.13	23.5	166.7	8.0	4.1	4.5	5	123	176	6	165
26	128.2	199.95	25.5	180.2	9.0	4.5	4.7	5	131	191	6	179
28	140.3	219.00	28.0	196.3	10.0	5.2	5.0	5	143	209	6	198
31	154.8	238.05	30.0	216.8	11.0	4.5	5.3	6	158	228	6	217
34	167.6	260.29	34.0	235.6	13.0	5.3	5.8	6	171	248	8	236
37	182.1	282.52	36.0	256.1	14.0	5.4	6.4	6	186	270	8	256
40	198.4	307.89	41.0	278.4	16.0	7.2	6.6	6	202	295	8	279
44	215.4	333.29	43.0	303.4	17.0	6.3	7.2	6	220	316	10	305
48	235.9	361.86	46.0	331.9	18.0	7.5	7.8	8	240	344	10	331
52	258.2	393.61	52.0	362.2	20.5	8.3	9.3	8	265	374	10	362
57	283.0	425.35	56.0	397.0	22.0	9.3	10.0	8	290	406	12	395
62	307.8	463.45	61.0	431.8	23.0	11.5	10.5	8	314	444	12	429
68	333.4	501.53	65.0	469.4	26.0	10.5	11.0	8	340	482	12	467
74	364.2	545.98	68.0	512.2	27.5	10.4	12.1	10	371	523	12	509
81	397.5	596.78	76.0	559.5	31.0	12.6	13.2	10	404	574	16	558
89	428.1	647.62	80.0	606.1	32.0	14.0	14.3	10	435	625	16	606
97	467.4	708.27	88.0	661.4	35.0	16.9	14.9	10	474	684	16	662
105	506.7	771.14	95.0	716.7	38.0	16.3	17.5	10	513	747	20	718
115	563.3	841.00	102.0	793.3	42.0	16.5	19.0	12	570	817	20	790
125	602.4	913.00	110.0	852.4	45.0	18.2	21.1	12	609	889	20	851

For inquiries and orders, please refer to our product code on page 14

**Non-Equalized**

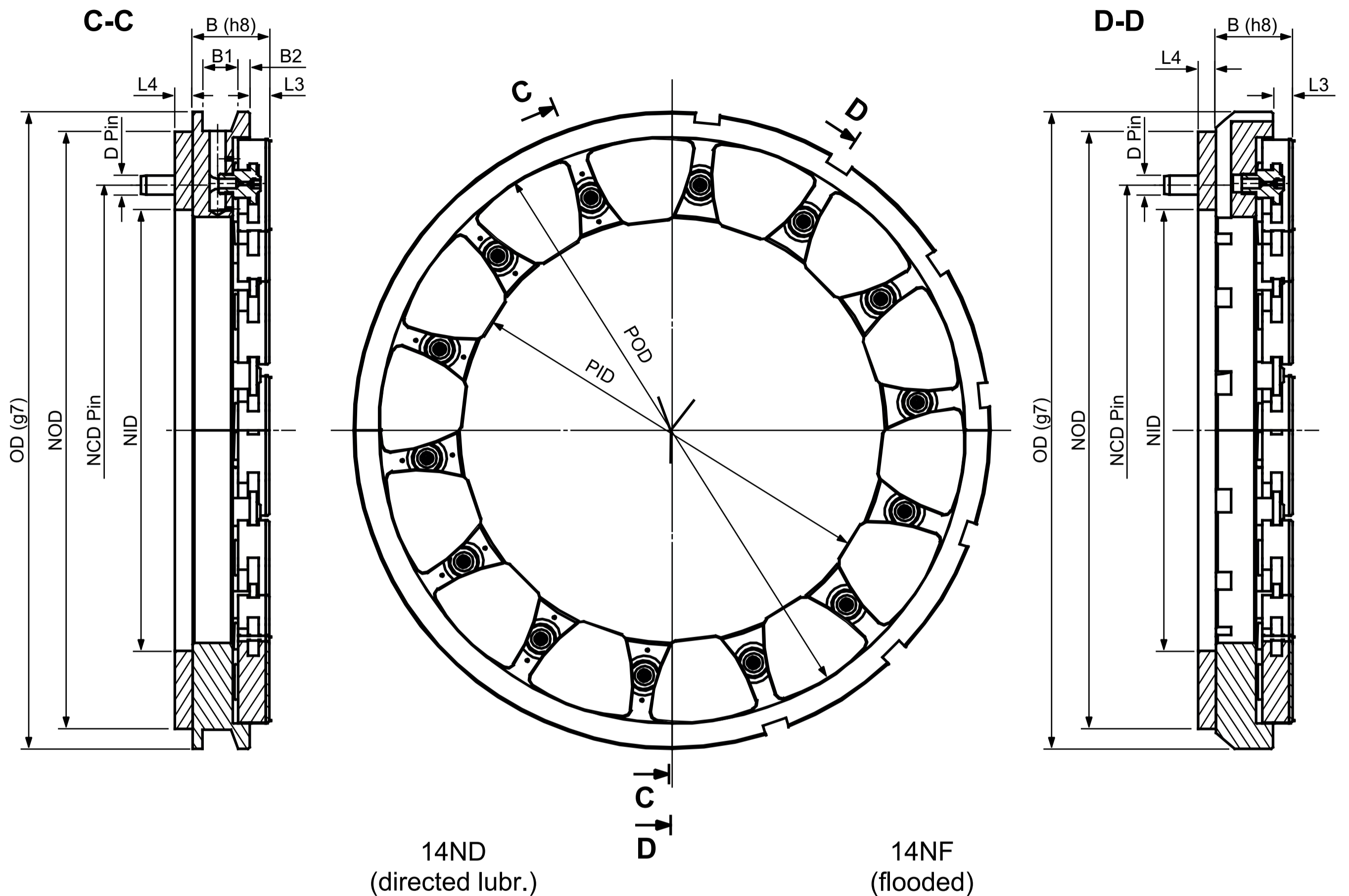

Size	PID	OD	B	POD	B1	B2	L3	L4	NID	NOD	D	NCD
23	120.7	184.13	21.26	166.7	8.0	4.1	4.5	5	127	174	6	151
26	128.2	199.95	23.95	180.2	9.0	4.5	4.7	5	135	189	6	162
28	140.3	219.00	25.54	196.3	10.0	5.2	5.0	5	147	206	6	177
31	154.8	238.05	27.12	216.8	11.0	4.5	5.3	6	163	225	6	194
34	167.6	260.29	28.71	235.6	13.0	5.3	5.8	6	176	244	8	210
37	182.1	282.52	30.30	256.1	14.0	5.4	6.4	6	191	266	8	229
40	198.4	307.89	31.89	278.4	15.0	5.8	6.6	6	208	291	8	250
44	215.4	333.29	35.06	303.4	17.0	6.3	7.2	6	226	311	10	269
48	235.9	361.86	38.94	331.9	18.0	7.5	7.8	8	246	339	10	293
52	258.2	393.61	42.11	362.2	20.0	8.3	9.3	8	272	369	10	321
57	283.0	425.35	45.29	397.0	22.0	9.3	10.0	8	297	400	12	349
62	307.8	463.45	48.46	431.8	23.0	11.5	10.5	8	321	438	12	380
68	333.4	501.53	51.64	469.4	26.0	10.5	11.0	8	348	476	12	412
74	364.2	545.98	54.81	512.2	27.5	10.4	12.1	10	379	515	12	447
81	397.5	596.78	61.16	559.5	31.0	12.6	13.2	10	412	566	16	489
89	428.1	647.62	64.34	606.1	32.0	14.0	14.3	10	445	617	16	531
97	467.4	708.27	73.70	661.4	35.0	16.9	14.9	10	484	674	16	579
105	506.7	771.14	80.05	716.7	38.0	16.3	17.5	10	523	737	20	630
115	563.3	841.00	86.40	793.3	42.0	16.5	19.0	12	582	805	20	694
125	602.4	913.00	95.45	852.4	45.0	18.2	21.1	12	621	877	20	749

For pad surface, see table page 14

# DESIGN OPTIONS & DESCRIPTION

## PARTLY EQUIPPED BEARINGS

For bearings that run at exceptionally low loads but high speeds, base rings with reduced number of pads may considerably decrease power losses and oil flows. This option is only applicable to non-equalized designs. It also can be adapted to suit any specific collar dimensions.

## BEARINGS WITH SOLID CARRIER RINGS

For equipment without a horizontal split line, such as barrel-type-pumps, we can provide bearings without the standard split line (bearing code suffix: -UN).

## BEARING MATERIAL

G-MD bearings are lined with ISO 14287 babbitt SnSb12Cu6Zn (equivalent to Tegostar™) as our standard. Upon request, we offer alternative linings such as ASTM B23 Grade 2 or thermoplastics. Pads and aligning rings are typically made of mild steel. If pad operating temperatures are elevated, a base material such as chrome copper (CrCu) can be used for the pads in order to improve heat transfer and protect the lining.

## SELF-EQUALIZING FEATURE

Each pad of a self-equalized bearing is designed to carry an equal amount of thrust load. To ensure this, upper and lower leveling plates are installed underneath the pads as shown below. Pads receiving excessive force transfer this to the lower leveling plates directly beneath them, and in turn raise the adjacent upper leveling plates and adjust the position of their corresponding pads. Kingsbury's 360° pad pivot is one of the important features of this arrangement.

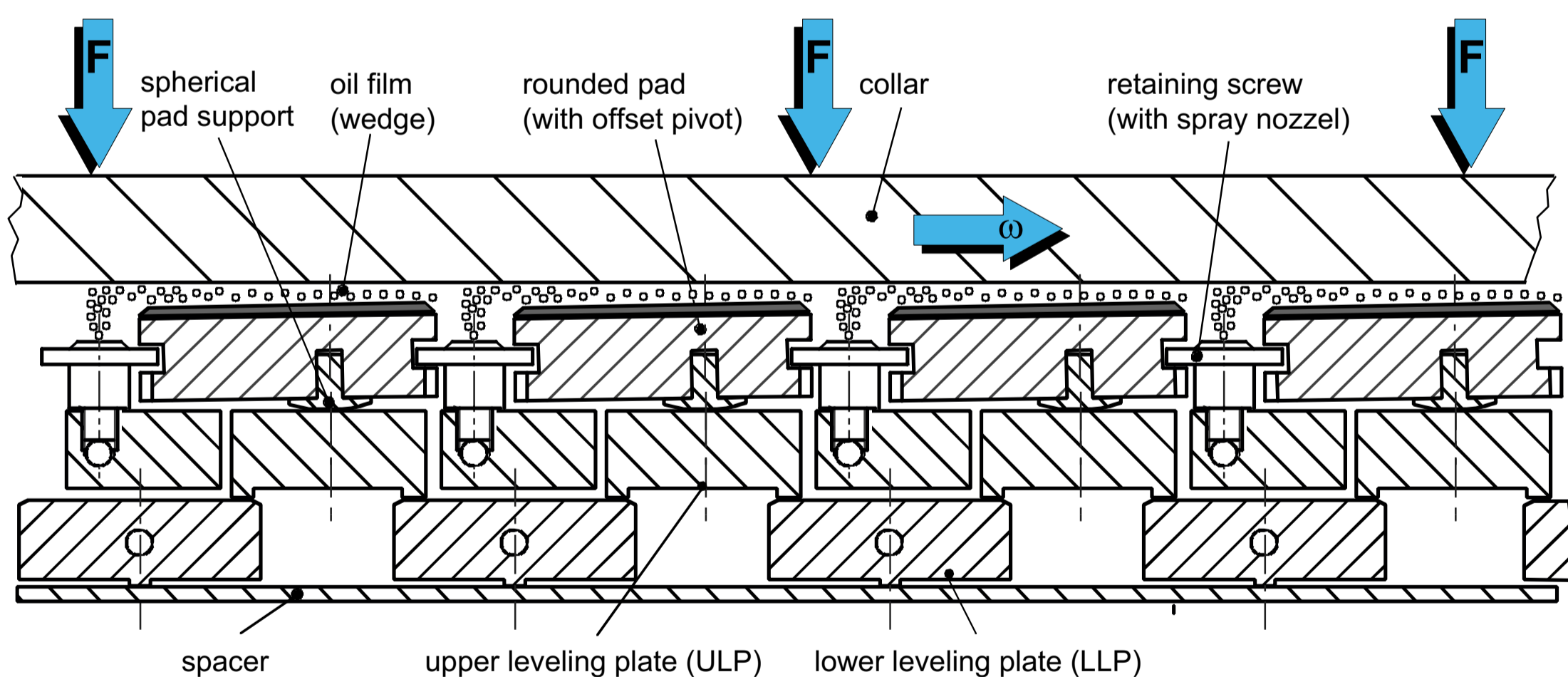

schematic flat projection of a self-equalized thrust bearing (G-MD style) with directed lubrication

## PAD SHAPE

The thrust pads are designed to optimize the oil exchange in the pocket between adjacent pads. Wide radii at the leading and trailing edges allow the use of the same pad in configurations of 6, 8, 11 and 14 pads. The leading and trailing edges also have grooves for pad retention. The corners of the pad are rounded in order to lower the maximum pad temperature and power loss. The pad thickness is optimized to mitigate performance issues due to elastic and thermal deformation.

# INSTRUMENTATION

## TEMPERATURE SENSORS

In most cases, the bearings are supplied only with drilled holes for customer-installed instrumentation.

The drilled hole is strategically located at the critical 75/75 position, close to the lining, in order to accurately gauge the operating temperature, and it is suitable for a standard sensor tip (diameter 3.2 mm).

The 75/75 location is in line with API-specifications and is typically the spot with the most demanding combination of pressure and temperature.

Upon request, other instrumentation hole sizes and locations can be supplied. Kingsbury can also accommodate a wide variety of sensor types (thermocouple, PT-100...), sensor heads and brands.

Our standard type is shown in the figure on the right. Deviations from this standard must be agreed to by both parties.

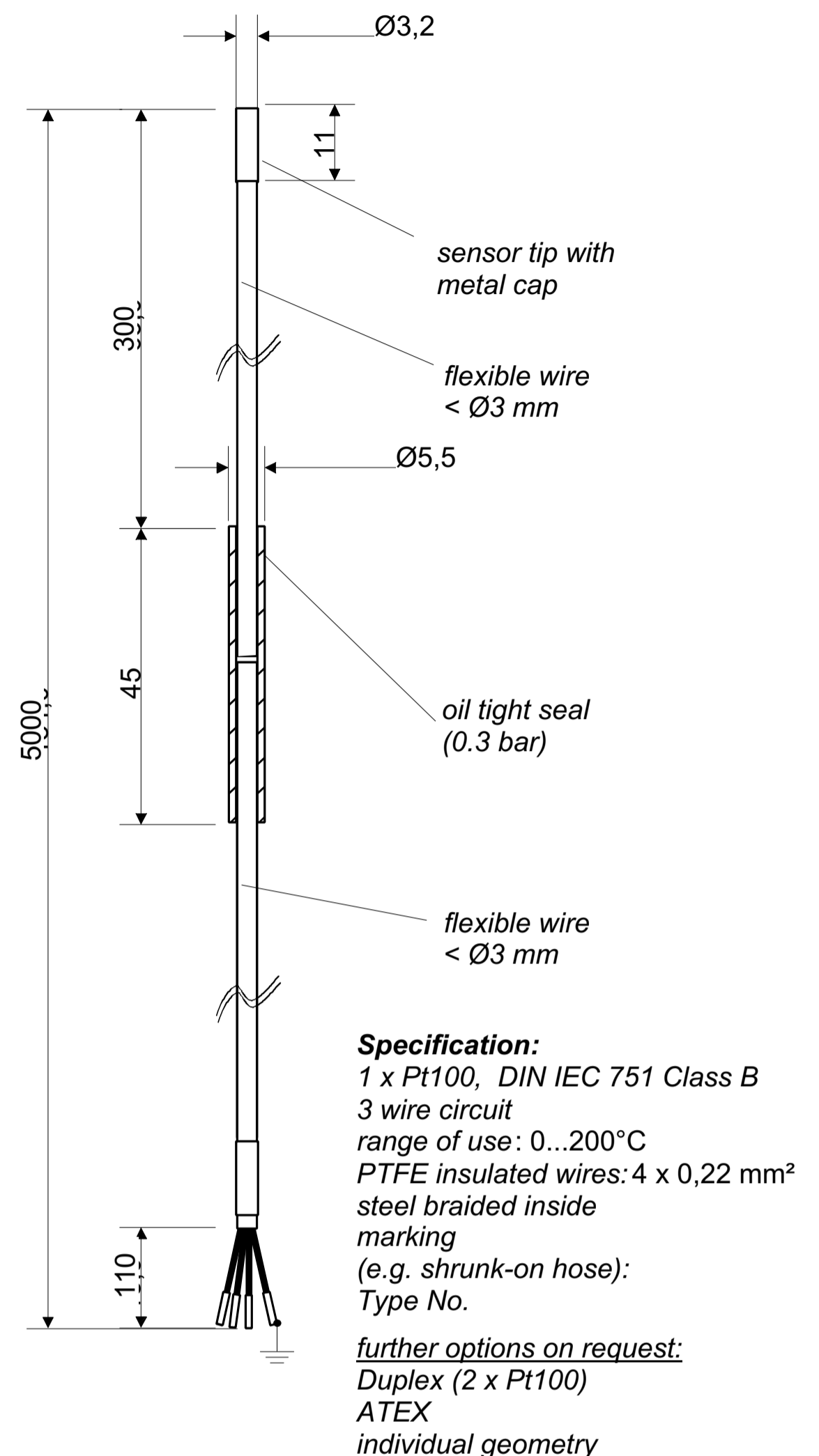

## LOAD CELLS

Load cells can be installed in bearings with pad sizes greater than 44 mm. These sensors are customized for Kingsbury to make the lead wires resistant to oil damage. They are of robust design and typically used in self-equalized thrust bearings.

The minimum number of load cells per bearing face is one, but we strongly recommend the use of at least two load cells. For accuracy within  $\pm 5 \%$ , every other pad must be instrumented.



## HIGH PRESSURE LIFT (HPL)

In the event of high loads at low speeds, High Pressure Lift (Jacking Oil) may be implemented. Get in touch with Kingsbury to discuss your particular needs.

# INSTALLATION

## END PLAY

Thrust bearings require clearance between pads and collar in order to create the load-carrying film. The total end play (sum of clearances on loaded and slack sides) has to allow for thermal growth, even in transient conditions.

The recommended total end play for G-MD bearings, as shown in the table on the right, corresponds to the pad size. It should be measured during bearing assembly by moving the shaft back and forth axially with a force between 5 and 10 % of the design load.

Depending on the application, on the distance between the two thrust bearings and on the customer's experience, the standard clearance may be adjusted to minimize power losses on slack side while maintaining accurate positioning of the shaft.

In order to limit collar deflection under load we recommend a minimum collar thickness according to the table on the right.

Pad size [mm]	Pad area [mm <sup>2</sup> ]	Total end play [mm] <sup>#)</sup>	Collar thickness [mm] <sup>§)</sup>
23	573	0,15	16
26	657	0,20	17
28	781	0,20	19
31	970	0,20	21
34	1164	0,25	22
37	1371	0,25	25
40	1609	0,25	27
44	1955	0,30	30
48	2303	0,30	32
52	2739	0,30	35
57	3319	0,35	38
62	3995	0,35	43
68	4708	0,35	48
74	5672	0,35	51
81	6830	0,40	56
89	8228	0,40	60
97	9901	0,40	67
105	11680	0,40	73
115	14322	0,45	78
125	16750	0,45	83

#) recommendation for standard  $\pm 0,05\text{mm}$   
§) minimum recommended thickness

## HOUSING FIT

For proper installation, Kingsbury GmbH recommends a loose fit of the bearing in the housing. In order to minimize the oil leakage, the ISO tolerance g7/H7 is commonly used.

## PRODUCT CODE

Kingsbury GmbH uses a generic bearing code that is able to describe most bearing types (journal, thrust or combined) as well as various design options. See the following example for a double acting thrust bearing with 8 pads, self-equalized, directed lubrication, offset pivot,  $\text{\O}356$  housing and spacer and shims.

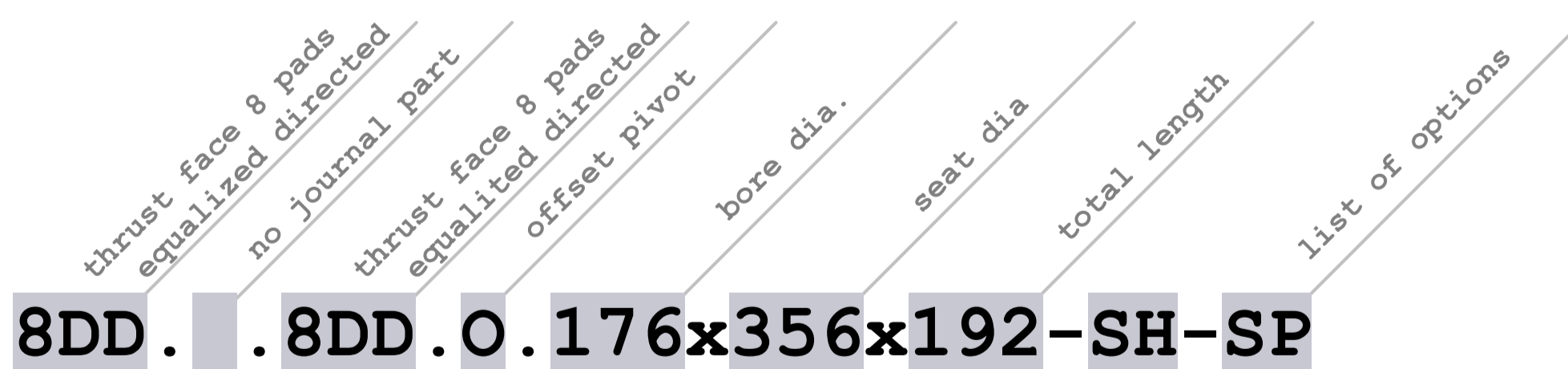

### Type of Thr-Brg:

**DD** : self-equalized directed lube  
**DF** : self-equalized flooded  
**ND** : non-equalized directed lube  
**NF** : non-equalized flooded

### Offset:

**O** : Offset pivot (uni-directional)  
**C** : Center pivot (bi-directional)

### Options:

**-CR** : CrCu-Pads  
**-HY** : HPL incl.  
**-IN** : Instrument. incl.  
**-LC** : Load Cell  
**-PK** : Peek-Pads  
**-SH** : Shim  
**-SP** : Spacer  
**-UN** : Unsplit

# BEARING CALCULATION

## BEARING CALCULATION

For calculation purposes, a short description of the bearing, e.g. Series 08x74, is sufficient to determine the geometry. Additional information, such as the shaft and assembly dimensions, the operational parameters (load and speed) and the oil supply conditions (VG class, inlet temperature, inlet pressure), is needed to evaluate the bearing performance. Depending on the calculation results and customer expectations, further selection iterations may be necessary.

Kingsbury GmbH is a member of the "Research Association for Combustion Engines FVV" in Germany and therefore uses the numerical program ALP3TA, in which diverse influences are considered, such as cavitation, 3-D variable oil viscosity and oil temperature, heat conduction into the shaft and bearing, heat transition into surrounding areas, 2-D variable pressure, transition from laminar to turbulent flow, oil back flow, type of oil supply and oil groove geometry, misalignment and pad deformation and the centrifugal force on the lubricant film.

In addition, we use our in-house code based on experimental test results gained over several decades of research and development at our facility in Philadelphia. Other codes such as COMBROS-A and ROMAC SHELL ThBrg are also available.

An example of a bearing calculation is shown on the right.



**THRUST BEARING CALCULATION**  
**SEGMENTLAGER-BERECHNUNG**

Version 2018ff - Nov.2025 / Dr. Medhioub , Dr. Beneke

---

MD S8x74 5800rpm / uni-direct.,  
 R.Beneke for John Doe Company  
 PO 2025-08001-010

CN26-03175-a100      -a999

Slack

Geometry Tilting Pad Thrust Bearing / Geometrie-Daten KSA-Lager			
Number of pads / Segmentzahl			
Inner diameter / Innendurchmesser	[ - ]	=	8      8
Outer diameter / Aussendurchmesser	[mm]	=	176,0      176,0
Length of pad / Tragende Segmentlänge	[mm]	=	324,0      324,0
Width of pad / Segmentbreite	[mm]	=	78,17      78,17
Pivot offset / Lage d. Segmentabstützung	[mm]	=	74      74
Total Pad Area / Gesamttragfläche	[ - ]	=	0,60      0,60
Base Material / Material d. Grundkörpers	[mm <sup>2</sup> ]	=	45379      45379
	[ - ]	=	Steel      Steel

---

Operational Data / Betriebsdaten			
Speed / Drehzahl			
Sliding-speed / Mittlere Umfangsgeschwindigkeit	[rpm]	=	5800      5800
Load / Lagerbelastung	[m/s]	=	75,9      75,9
Specific load / Spezifische Lagerbelastung	[N]	=	100000      ( 3580 )
Oil type / Ölsorte	[MPa]	=	2,2      ( - )
Oil inlet temperature / Ölzufuhrtemperatur	ISO VG	:	32      32
	[°C]	=	50,0      50,0

---

Results of Calculation / Rechenergebnisse			
Oil exchange factor / Frischölerneu.-Faktor	[ - ]	=	0,360      0,104
Babbitt Temp. at API location / T <sub>API</sub> (75/75)	[°C]	=	80,8      64,6
Max. Babbitt Temp. / T <sub>max</sub> (trailing edge)	[°C]	=	88,7      67,0
Minimum film height / Min. Schmier-spalt	[µm]	=	32,4      173,2
Min. permissible film / min. zuläss. Spalt	[µm]	=	11,2      11,2
Film at pad support loc. / h am Abstützpunkt	[µm]	=	65,2      281,3
Height of tilt. pad wedge / Keiltiefe Segment	[µm]	=	82      270,4
Total pad curvature / Segmentwölbung	[µm]	:	12,1      5,4
Rate of oil feed flow / Ölzufuhr	[l/min]	=	62,0      62,0
Power loss / Verlustleistung	[kW]	=	38,4      19,9
Max. hydrodyn. pressure / Max. Lagerdruck	[MPa]	=	6,31      0,42
Mean oil film temp. / Mittlere Schmierfilmtemp.	[°C]	=	79,6      66,1
Mean oil viscosity / Mittlere Ölviskosität	[mPas]	=	6,73      9,9
Rise of oil temperature / Ölerwärmung	[K]	=	19,1      9,9
Stiffness-coeff. in load direct.	[N/mm]	=	4488928      76321
Damping-coefficient in load direct.	[Ns/mm]	=	2678      63
Percentage of laminar flow over pad	[%]		49      3

---

Footnote: Checked and ok!

29-Feb-26 14:10:41



**Kingsbury GmbH**  
Wilhelm-Lambrecht-Str. 2  
37079 Göttingen  
GERMANY

T: +49 551.999553-0  
F: +49 551.999553-29  
GmbH@kingsbury.com



**Kingsbury, Inc.**  
10385 Drummond Road  
Philadelphia, PA 19154  
USA

T: +1-215-824-4000  
F: +1-215-824-4999  
Sales@kingsbury.com

[www.kingsbury.com/de](http://www.kingsbury.com/de)