

# Equalizing Thrust Bearings

COMPREHENSIVE DESIGN GUIDE



## CONTENTS

INTRODUCTION .....	3
SECTION I: ELEMENTS AND DESIGN OF KINGSBURY THRUST BEARINGS .....	5
SECTION II: USING KINGSBURY DESIGN FEATURES .....	9
SECTION III: HOW TO SELECT KINGSBURY THRUST BEARINGS ..	12
SELECTION TABLES: STYLE J, B, E BEARINGS, ENGLISH.....	14
SELECTION TABLES: STYLE J, B, E BEARINGS, METRIC.....	18
SELECTION TABLES: STYLE S BEARINGS, ENGLISH .....	22
SELECTION TABLES: STYLE S BEARINGS, METRIC .....	30
ESTIMATING BABBITT TEMPERATURES ..	38
OIL DISCHARGE CONFIGURATIONS.....	42
OIL CONTROL RINGS .....	43
INSTRUMENTATION.....	46
SHAFT AXIAL POSITION INDICATION .....	48
SHOE RETENTION OPTIONS .....	49
TYPICAL KINGSBURY THRUST BEARING ARRANGEMENTS.....	50
NOTES ON SELECTING KINGSBURY THRUST BEARINGS.....	51
GENERAL INFORMATION ON KINGSBURY THRUST BEARINGS.....	52
REPAIR AND SERVICE .....	54



*Philadelphia Plant and Corporate Offices*



*Oshkosh, WI Plant*



*Hatboro, PA Repair & Service Division*



## INTRODUCTION

Kingsbury thrust bearings are a product of many years of design refinement and application experience. In this Design Guide we have condensed our years of experience into guidelines and recommendations that will help you to apply Kingsbury thrust bearings with confidence, whether you are an experienced designer or a novice faced with your first bearing application.

The Guide contains three sections that will guide you to a proper thrust bearing selection. Each section highlights special design considerations and offers suggestions you may find valuable in your design efforts.

The first section presents information that will help you understand the fundamentals of equalizing fluid film thrust bearings. Section II reviews the design features of our thrust bearings and the accessories available for monitoring bearing performance. In Section III, we have provided step-by-step guidelines for selecting the proper Kingsbury bearing for your particular application. If you desire a better understanding of bearing technology and its evolution, please request Kingsbury's General Guide to the Principles, Operation and Troubleshooting of Hydrodynamic Bearings.

While this guide concentrates on equalizing thrust bearings intended for use on horizontal shafts, the same shoe and leveling plate components can be mounted in a modified base ring suitable for vertical shaft applications. These shoe and leveling plate sets can also be mounted in combination thrust and journal bearings.

In a Design Guide such as this one, it is impossible to include every style and type of product that is available. For instance, we manufacture shoe type journal bearings for use alone or in combination with our thrust bearings; we can provide bearings larger than those shown in the following pages; and we can design special bearings to fit particular application requirements. If you have a special bearing requirement not covered in this catalog, please send your specifications to us and we will make the appropriate bearing recommendations.

## AN HISTORICAL NOTE

Since 1912, Kingsbury has enjoyed recognition as the leader in the design and manufacture of equalizing fluid film thrust bearings. We owe our success to the inventive spirit, diligence, and perseverance of our founder, Dr. Albert Kingsbury. In all of his roles, as mechanical engineer, college professor, inventor and businessman, Dr. Kingsbury made outstanding contributions to the bearing industry. His most notable achievement, the pivoted shoe thrust bearing, has dramatically improved the performance of many machines that operate at high speeds under heavy loads.

Dr. Kingsbury's odyssey began in 1884, when he entered Ohio State University at Columbus as a freshman, to study mechanical engineering. At the end of his sophomore year, he left Ohio State to work as a draftsman and serviceman for a company that manufactured wire drawing machines. A year later, in the fall of 1887, he enrolled in Sibley College, Cornell University, as a junior in mechanical engineering, and continued there until graduation in 1889.

It was during his junior year at Cornell that he first recognized the need for improved thrust bearings. After graduation, he continued his study of thrust bearings while a professor of mechanical engineering at New Hampshire College of Agriculture and the Mechanic Arts (now the University of New Hampshire). Using Osborne Reynold's theory of lubrication, Dr. Kingsbury built the first centrally pivoted thrust bearing and proved it operational in 1898. Several years later, while employed as a practicing engineer, Dr. Kingsbury found his first opportunity to apply his unique bearing design. Finally, in 1910, the U.S. government awarded him a patent for his thrust bearing.

In 1912, Dr. Kingsbury entered into business for himself, ultimately founding the Kingsbury Machine Works in Philadelphia, to manufacture the now famous Kingsbury thrust bearing. Since those early days, we have grown steadily, developed new bearing designs, improved bearing performance, and adapted our designs and manufacturing techniques to meet the requirements of successively more demanding applications.

Our corporate offices, engineering staff, large and medium size manufacturing operations, and our research and development laboratory are still located in Philadelphia, but today we also operate a second plant in Oshkosh, WI devoted to the manufacture of small and medium size precision bearings. In addition, Kingsbury maintains a facility in Hatboro, PA, dedicated to the repair and service of all types and brands of babbitted bearings (see page 54).

As he built his company, Dr. Kingsbury imbued it with his sense of diligence, attention to detail, pride in quality, and devotion to customer service—traits that have remained hallmarks of Kingsbury, Inc. through the years.

## SECTION I ELEMENTS AND DESIGN OF KINGSBURY THRUST BEARINGS



### EQH Equalizing Thrust Bearing

Beginning with a fundamental review of the Kingsbury thrust bearing, this section lists basic bearing elements and how they work, as well as design options and accessories.

### How Kingsbury's Thrust Bearing Works

A thrust bearing transmits axial shaft loads into the foundation or machine support of rotating apparatus. Our equalizing thrust bearing actually transmits the load through a self-renewing film of oil during operation and a unique force-balancing action distributes the load across the shoes. Working surfaces touch each other only during start-up and shut-down. Otherwise, these surfaces are separated by the fluid film, so surface wear is minimal, and bearing life dramatically lengthened.

The Kingsbury thrust bearing offers many operating advantages, including:

- Excellent shock absorbing capacity
- Superior damping characteristics
- Life span equal to that of the machine
- Versatility in application
- Performance monitoring capability

### Basic Elements

Here is a quick review of the basic elements in a Kingsbury equalizing fluid film thrust bearing:

**Rotating Thrust Collar** The forged steel collar, which is rigidly attached to the shaft or rotor, transmits the thrust load from the rotating shaft to the bearing shoes.

The collar faces are ground, then lapped flat and smooth to reduce frictional loss and increase load capacity.

*Design Option: The collar may be mounted separately or formed integral with the shaft or rotor.*



**Rotating Thrust Collar**

### Stationary Pivoted Shoes

The shoes in our thrust bearings (also known as pads or blocks) have three parts:

**Shoe Body** Shoe thickness has been selected to reduce the amount of thermal and elastic deformation. For a centrally pivoted shoe, a certain amount of thermal or elastic crowning is necessary for the thrust shoe to carry load, whereas excessive crowning reduces load-carrying capacity. Therefore, we have carefully optimized our designs so that the elastic or thermal crowning of a Kingsbury thrust shoe yields maximum load-carrying capacity.

**Babbitt Face** The thickness of the babbitt has also been optimized to increase compressive strength of the babbitt while maintaining the very desirable embedability characteristic of babbitt. This material allows small amounts of foreign particles that are in the lubricating oil to embed themselves in the babbitt rather than score or damage the rotating collar.

**Shoe Support** The spherical pivot on Kingsbury thrust shoes allows the shoe to tilt not only in the direction of rotation but also in the radial direction, compensating for some misalignment between the thrust bearing face and the operating thrust collar. The ability of a shoe to pivot as well as to tilt increases load-carrying capability at all shaft speeds. The thrust shoe pivot, or shoe support, and the upper leveling plate where the thrust shoe pivot makes contact, are both made of high carbon steel, heat-treated to Rockwell 50C, to prevent damage to the pivot contact areas.

*Design Options:* While the standard position of the hardened steel support is at the center of the shoe, this support can be offset in the direction of rotation. For details, contact the Kingsbury's Engineering Department.

*Special shoe body materials, such as copper alloy, can be supplied to improve thermal performance.*

*If necessary, the shoes can be retained to facilitate installation. For details see page 49.*



**Pivoted Shoe Anatomy**

### Stationary Base Ring and Leveling Plate Assembly

Made of cast, plate, or forged steel, the base ring holds the shoes and leveling plates in their operating positions. An oil inlet annulus, at the back of the base ring, distributes oil to radial slots in the ring's back face.

This assembly uses the equalizing principle developed by Dr. Albert Kingsbury to distribute the load equally over the bearing shoes and transmit the load to the bearing housing.

*Design Options:* Bearing load can be measured by inserting strain gauge load cells in the upper leveling plates or thrust shoes. This feature can be retrofitted to installations in the field. For further information, see page 47.

*The base ring may be drilled and tapped for mounting shim packs or filter plates, if necessary. Contact Kingsbury for full details.*

**Leveling Plates** The equalizing feature of the Kingsbury thrust bearing allows each shoe to carry an equal amount of the total thrust load. The leveling plate feature reduces the chance of

one shoe being more highly loaded than another shoe. The leveling plates, combined with the spherical shoe support, also ensure that the thrust bearing face becomes perfectly aligned with the rotating thrust collar.

### Number of Thrust Shoes

The standard Kingsbury thrust bearing usually has six or eight pivoted thrust shoes held in the base ring carrier. In the base ring there are upper leveling plates and lower leveling plates to

Study these illustrations to see how the shoe and leveling feature work.

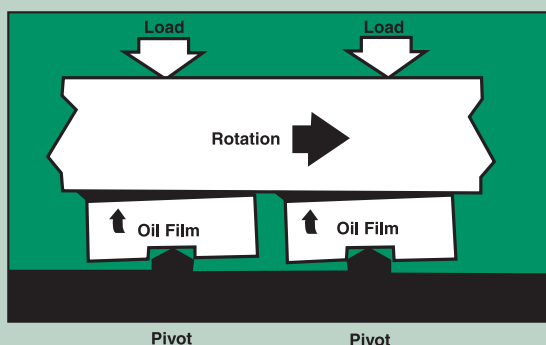

Fig. 1

Fig. 1 The shoe is loosely constrained so free pivoting can occur about the circumferential and radial axes. When subjected to the hydrodynamic forces of the moving fluid film, the shoe inclines, forming a converging flow channel. Pressure is generated as the fluid is carried through this channel by adhesion to the collar. The pressure field transmits the load from the collar to the shoe.

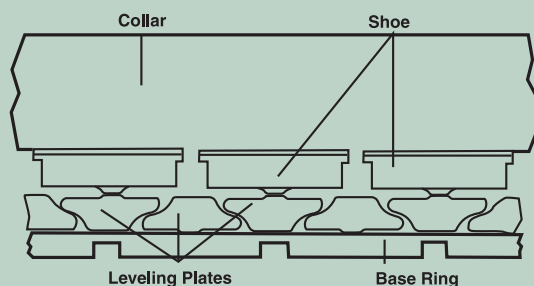

Fig. 2

Fig. 2 Notice that each shoe has its own upper leveling plate and shares two lower leveling plates. To understand how the assembly works, keep in mind that the load transmitted through the oil film to each shoe is inversely proportional to the oil film thickness. Thus, equalization is achieved when the leveling plates lower the overloaded shoe and raise the underloaded shoe. As the leveling plates intermesh, the load on adjacent shoes is equalized. This action also compensates for minor housing deflections and misalignment between the housing's supporting wall and the collar's face.

**Note:** Leveling plates do *not* compensate for collars which are not square with the shaft.

equalize the thrust load. When the number of thrust shoes increases beyond eight shoes, the alignment and equalizing efficiency of the bearing is diminished and peak shoe temperatures could increase.

**Design Features**

The thrust bearings in this catalog have been designed to be used with many types of machines or applications. The thrust shaft can rotate clockwise or counterclockwise, or bidirectionally, if necessary. These bearings can be used with almost any type of oil, and, due to the equalizing

capability of the bearings, only reasonable care has to be taken in assembly to assure that the bearings are aligned properly. We manufacture many of these bearings in sufficient quantities to provide economical advantages to the user, and we stock them at our Philadelphia, PA and Oshkosh, WI plants to facilitate prompt delivery.

Thrust bearings that lack pivoted thrust shoes and the equalizing feature of leveling plates cannot carry the same loads as Kingsbury bearings that incorporate these design

advantages. This is because proper alignment of the bearing and housing relative to the thrust collar is difficult, and because accumulated manufacturing tolerances cannot permit the fine precision necessary to accommodate higher loads.

Kingsbury bearings, on the other hand, have been designed so that they offer not only maximum load capacity for the lifetime of the machine in which they're installed, but also a series of refinements that add versatility to their application.





## SECTION II USING KINGSBURY DESIGN FEATURES

Since 1912, we have gained unequaled experience in designing and manufacturing thrust bearings. This section details design features which we developed to improve your machine's performance. Please see discussion starting on page 42 for such items as oil control rings, strain gauge load cells, and retained thrust shoes. That section explains how these features work, and when you should use them.

### Lubrication

For Kingsbury thrust bearings to operate safely and efficiently, continuous self-renewing oil films must be present between the shoes and collar.

The oil supplied to the bearing should be cooled

and filtered, so that the average particle size is less than the bearing's minimum film thickness. The typical oil flow path is shown below.

### End Play

To understand end play, or axial clearance, picture a double thrust bearing (one on each side of the collar). End play is the distance the thrust collar can be moved between the bearings during installation while applying load to either bearing.

**Note:** End play isn't an exact dimension. The shaft's maximum end play is limited to the smallest clearance between the stationary and rotating machine elements, while the shaft's minimum

end play must be sufficient to prevent excessive power loss in the unloaded thrust bearing.

Any time a double thrust bearing is installed, end play must be provided to allow for an oil film to form in each bearing, and thermal expansion of the bearing elements.

**Design Option:** Normal thrust bearing overall height tolerances are about  $\pm 0.04$ " (1.0 mm). To obtain suitable end play, filler plates, machined to adjust for the tolerances of the thrust bearing and bearing housing, should be installed. If it isn't practical to use filler pieces in the bearing assembly, thrust bearings can be provided with height tolerances of  $\pm 0.005$ " (0.13mm) on special order.

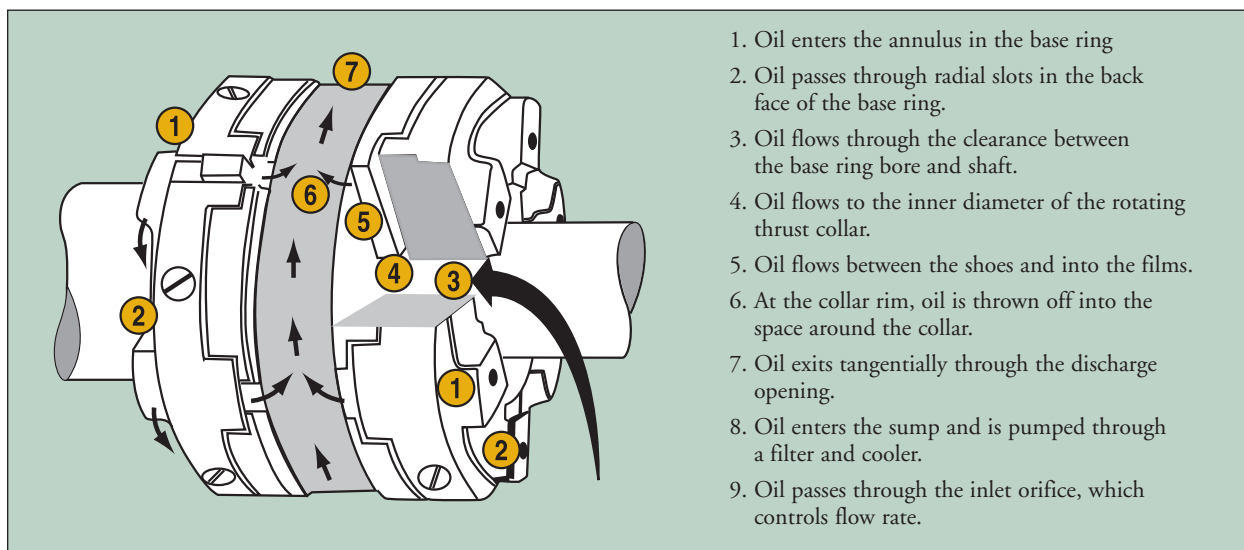

Typical Oil Flow Path

### Setting End Play (EP)

Filler plates (or shims) are used most often to set both end play and the axial position of the rotating elements. To determine how thick the filler pieces should be, use the figure below and this equation for a double thrust bearing application:

$$BC = F_1 + H_1 + X + EP + H_2 + F_2 \text{ or}$$

$$F_1 + F_2 = BC - (H_1 + H_2 + X + EP)$$

**Important:** While the total filler dimension ( $F_1 + F_2$ ) is easily determined, the individual thickness dimensions  $F_1$  and  $F_2$  must be selected to position the shaft collar for proper spacing of the stationary and rotating machine elements. Remember that the operating film thickness of the loaded bearing will be much less than that of the unloaded bearing, causing the collar centerline to shift toward the loaded bearing during operation.

**Design Tip:** Allow for a slight, permanent set in the bearing elements by specifying a plus or a minus range for end play.

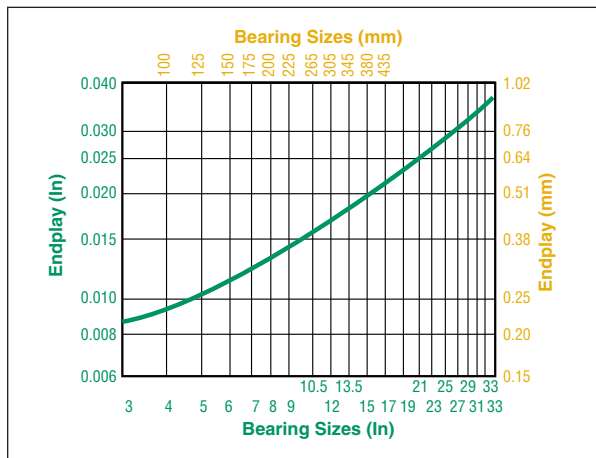
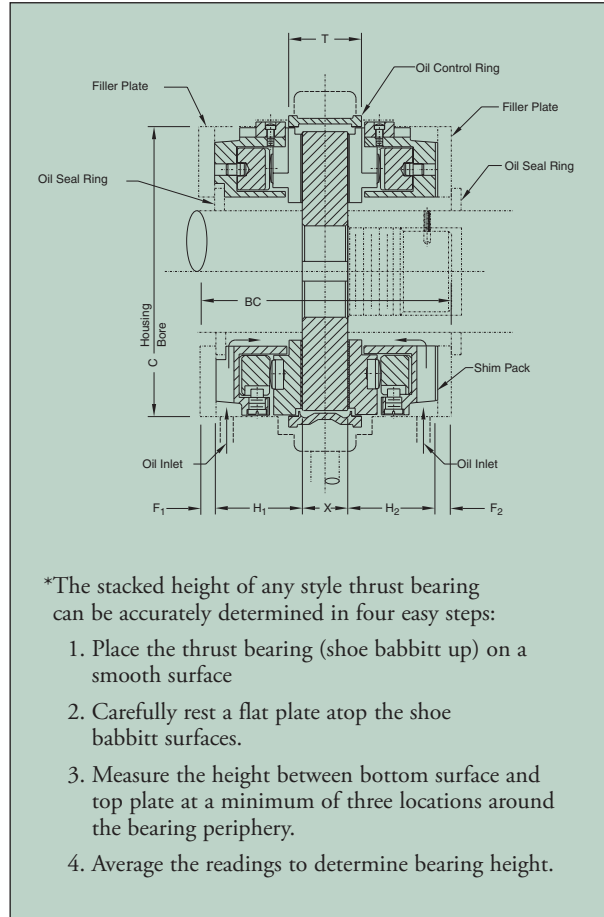

Recommended Nominal End Play

### Setting End Play

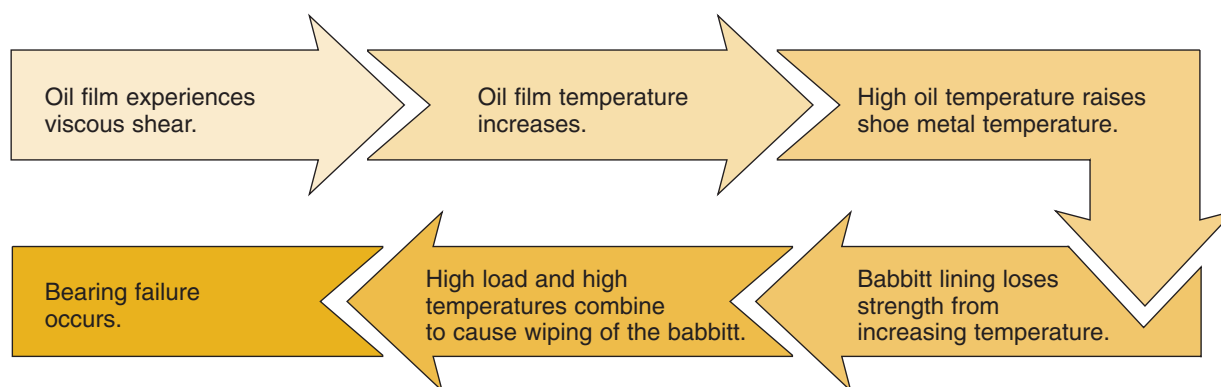

Fig. 13-1

### Temperature Measurement

Any change in load, shaft speed, oil flow, oil inlet temperature, or bearing surface finish affects bearing temperature. In turn, excessively high temperatures in the shoe babbitt metal can lead to costly bearing failures caused by wiping of the babbitt.

As you would expect, computer programs are available which analyze oil film pressure, oil temperature, oil viscosity, and shoe deflection. However, these programs yield temperature predictions which are dependent upon several assumptions regarding film shape, hot oil carry-over, and average viscosity.

Fortunately, a more reliable method of assessing bearing performance exists. We offer shoes with built-in temperature sensors so you can continually monitor the shoe's surface temperature. This way, metal temperature (the most accurate indicator of the bearing condition) is known at a

glance. Remember, discharge oil temperature is indicative only of the inlet oil temperature and the friction power loss in the bearing.

#### How the temperature sensor works

The temperature sensor, whether it is a thermocouple or a resistance temperature detector (RTD), measures the metal temperature between the shoe's center and trailing edge, where the highest, most critical temperature reading occurs. The sensor can be epoxied in the shoe body or at the 75/75 position (see illustration page 46). The sensor is located 75% of the shoe length in the direction of rotation from the leading edge, and the 75% of the shoe width measured radially outward from the shoe's inner diameter.

*Note:* Temperature sensors should not be embedded in the babbitt, because babbitt surface distortions could occur.

*Design Option:* Temperature sensors can be mechanically mounted to facilitate replacement. Spring loaded sensors, dual elements, and other types of special sensors are also available.

Grooves can be provided in the shoes and base ring to accommodate the lead wire between the sensing element and the wire exit for the bearing housing.

*Note:* The load direction and shaft rotation must be defined accurately. Temperature varies across and through the shoe, so the sensor must be located properly. For these reasons, we have developed standard sensor locations, such as the 75/75 position for thrust bearings.

Shoe reference temperatures and shoe temperature pattern variations are described starting on page 38, as well as a detailed report on the temperature tests we have conducted on our thrust bearings.

# SECTION III

## HOW TO SELECT KINGSBURY THRUST BEARINGS

### Style Differences Among Kingsbury Thrust Bearings

Style	Characteristics
J	6-shoe design Axial length is greater than style B's to provide increased oil capacity. Manufactured in large quantities. Stocked in sizes up to 17 inches. Economical bearing capacity.
B	6-shoe design Oil slots not as deep as style J's and shorter in axial length. Manufactured in large quantities. Stocked in sizes up to 19 inches. Economical bearing capacity.
E	8-shoe design Interchangeable with style B. Oil slots are deeper than other styles; therefore provide higher oil capacity.
S	Axial length is shorter than style B's. Accommodates larger diameter, high speed shafts. Large bearings, various number of shoes

### Separable Collars

Each of the above bearing styles can be furnished with separable collars. Standard collar bores and keyway sizes are shown in the dimension tables, but special bores and keyway sizes can be furnished upon request. We recommend that collars have a close sliding fit on the shaft, 0.001" – 0.003" (0.03 – 0.08mm).



### Bearing Assembly Codes

Bearing Code	Number of Shoes	Usual Size Range, inches
JHJ	6x6	4-17
JH	6	4-17
JJ	6x6	4-17
J	6	4-17
BHB	6x6	4-27
BH	6	4-27
BB	6x6	4-27
B	6	4-27
EHE	8x8	6-27
EH	8	6-27
EE	8x8	6-27
E	8	6-27
SHS	*	3-72
SH	*	3-72
SS	*	3-72
S	*	3-72

### Here's what the codes mean:

- Kingsbury's four thrust bearing styles are J, B, E and S.
- An H in the code means a separate collar is furnished by Kingsbury.
- A single 6 or 8 designates a bearing with that number of shoes, on one side of the collar only.
- A 6x6 or 8x8 designates a bearing with that number of shoes, on both sides of the collar.
- (\*) indicates that the number of shoes varies with the thrust bearing that is being selected.

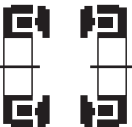
### Examples

Double Bearing with Collar	Double Bearing without Collar	Single Bearing with Collar	Single Bearing without Collar
JHJ BHB EHE SHS 	JJ BB EE SS 	JH BH EH SH 	J B E S 

## ABOUT THE SELECTION PROCESS

Thrust load, shaft RPM, oil viscosity and shaft diameter will determine the bearing size selected.

Size the bearing for normal load and speed when transient load and speed are within 20% of normal conditions. If transients exceed 120% of normal, please consult our engineering department for specific recommendations.

The selection curves for load capacity, friction power loss, and oil flow requirements in this catalog are divided into English and Metric groupings and are based on an oil viscosity of 150 SSU @ 100°F (ISO VG32), with an inlet oil temperature of 120°F (50°C). We recommend ISO VG32 oil viscosity for moderate and high-speed applications. For performance information on other oil viscosities consult our engineering department for assistance in bearing selection.

### Step-by-Step Sizing

1. Enter the load capacity curves, with the required bearing rated load and move horizontally along the corresponding rated load line until it intersects the vertical line representing the shaft RPM. The bearing size curve immediately above the intersection is the selected bearing size.

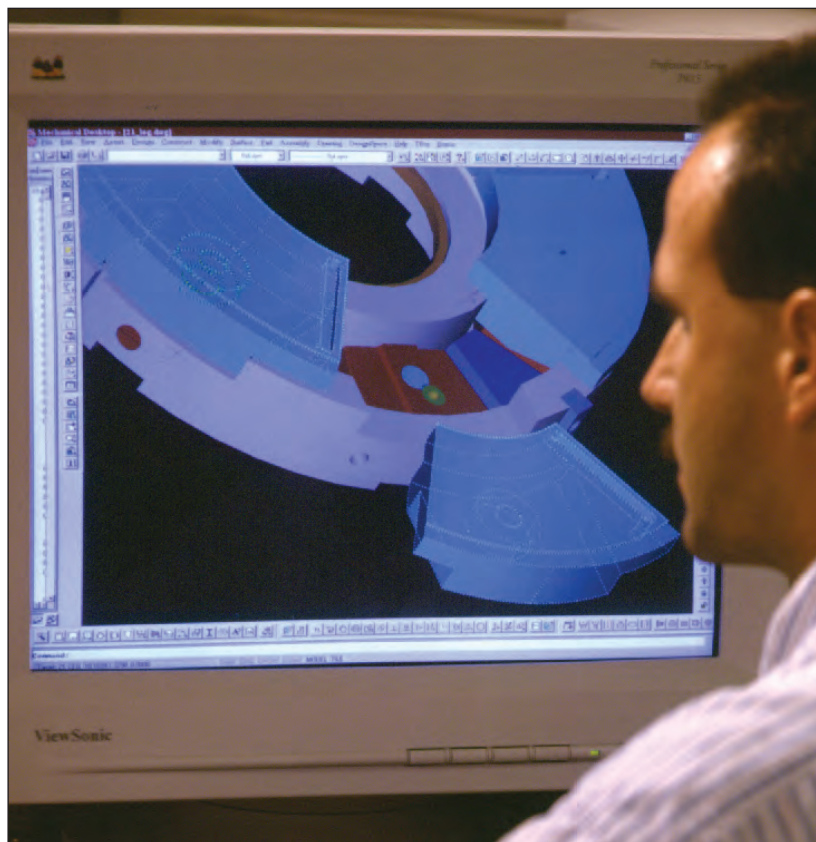

2. Next, find the selected bearing dimensions. Check to see if your shaft diameter is smaller than the maximum shaft diameter listed for the selected bearing.

3. Enter the power loss and oil flow curves, with the selected bearing size and the normal RPM to determine the power loss and oil flow.

4. Using the shoe temperature curves, determine whether the shoe temperatures are within acceptable limits.

If you need help selecting a bearing, contact Kingsbury's engineering department.

## LUBRICATION REQUIREMENTS

Kingsbury bearings are designed to operate with a continuous supply of oil to the bearing shoe faces. An orifice is required before the bearing to properly regulate flow and pressure (see page 52, "Pressure and Flow Orifice"). The oil supplied to the bearing should be cooled and filtered (25 micron filter is normally recommended).

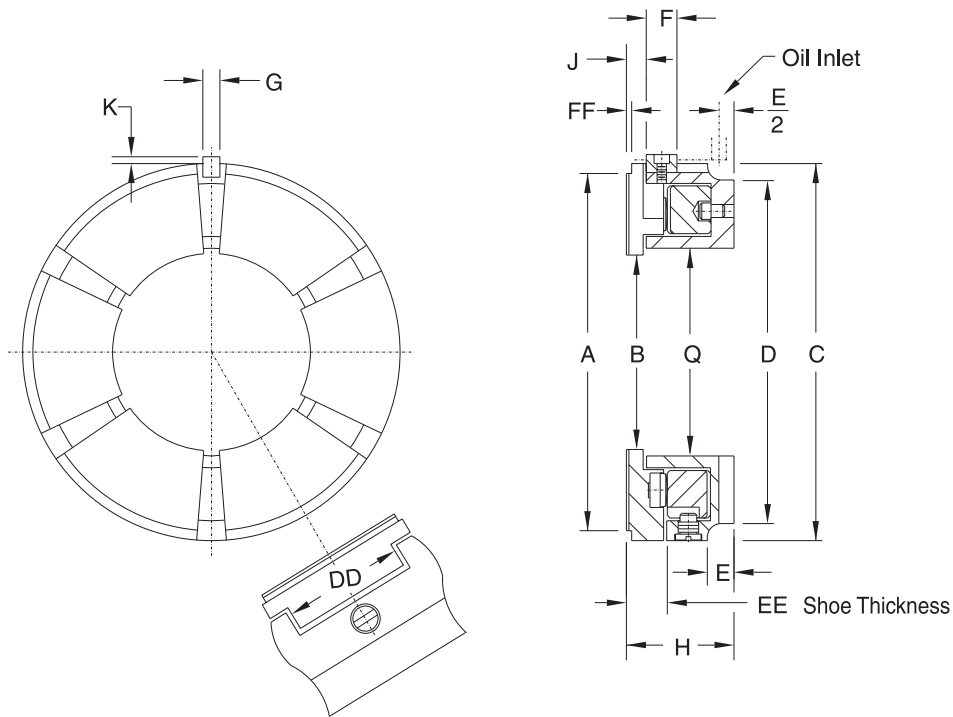

### Style J, B, E Bearings—English Units (inches)

Bearing Size	4	5	6	7	8	9	10.5	12
No. of Shoes 6 for J&B 8 for E								
Area (in <sup>2</sup> )	8	12.5	18.0	24.5	31.4	40.5	55.1	72.0
A – Babbitt O.D.	4.00	5.00	6.00	7.00	8.00	9.00	10.50	12.00
B – Babbitt I.D.	2.00	2.50	3.00	3.50	4.12	4.50	5.25	6.00
H – Bearing Height (J)	1.44	1.75	2.06	2.38	2.69	3.00	3.38	3.75
H – Bearing Height (B)	1.38	1.62	1.88	2.12	2.38	2.69	2.94	3.25
C – Bearing O.D.	4.375	5.375	6.375	7.375	8.375	9.375	11.000	12.500
Q – Base ring I.D.	2.19	2.75	3.25	3.75	4.31	4.88	5.69	6.50
D – Oil annulus dia.	4.12	4.94	5.94	6.75	7.62	8.62	10.00	11.56
E – Oil annulus depth (J)	0.38	0.50	0.59	0.69	0.82	0.88	1.00	1.19
E – Oil annulus depth (B)	0.31	0.38	0.40	0.44	0.51	0.57	0.56	0.69
F – Bearing key, length	0.38	0.56	0.66	0.81	0.94	0.94	1.12	1.19
G – Bearing key, width	0.25	0.31	0.38	0.38	0.44	0.44	0.50	0.56
J – Collar to key	0.28	0.31	0.38	0.47	0.50	0.56	0.62	0.69
K – Key projection	0.12	0.16	0.19	0.19	0.19	0.19	0.22	0.22
M – Separate shaft dia.	1.75	2.25	2.75	3.25	3.75	4.25	4.88	5.62
N – Integral shaft dia.	1.62	2.12	2.62	3.12	3.62	4.12	4.75	5.50
P – Max dia. over fillet	1.83	2.41	2.92	3.42	3.91	4.42	5.12	5.87
R – Dia. through base ring	1.94	2.50	3.00	3.50	4.00	4.50	5.25	6.00
S – Shaft lgth @ shoe I.D.	0.50	0.62	0.75	0.88	1.00	1.12	1.25	1.38
X – Collar thickness	0.88	0.88	1.00	1.25	1.38	1.50	1.75	2.00
Y – Collar dia.	4.12	5.12	6.12	7.12	8.12	9.12	10.69	12.19
Z – Collar bore	1.250	1.750	2.125	2.500	3.000	3.500	4.125	4.750
T – Collar key depth	0.16	0.19	0.19	0.25	0.31	0.31	0.38	0.38
V – Collar key width	0.31	0.38	0.38	0.50	0.62	0.62	0.75	0.75
W – Collar chamfer	0.06	0.06	0.06	0.06	0.06	0.06	0.09	0.09
DD – Straddle mill	1.28	1.59	1.97	2.34	2.72	3.03	3.19	3.97
EE – Shoe thickness	0.500	0.625	0.750	0.875	1.000	1.125	1.250	1.375
FF – Shoe relief	0.12	0.16	0.16	0.19	0.22	0.31	0.28	0.34
Weight (Lbs) Bearing	3.4	5.6	9.0	14.8	20.9	30.5	44.9	64.4
Weight (Lbs) Collar	3	4.5	7.5	12.5	17.5	23.6	37.7	56
Weight (Lbs) Spare shoes	1.1	2.1	3.5	5.5	7.8	11.2	18	25

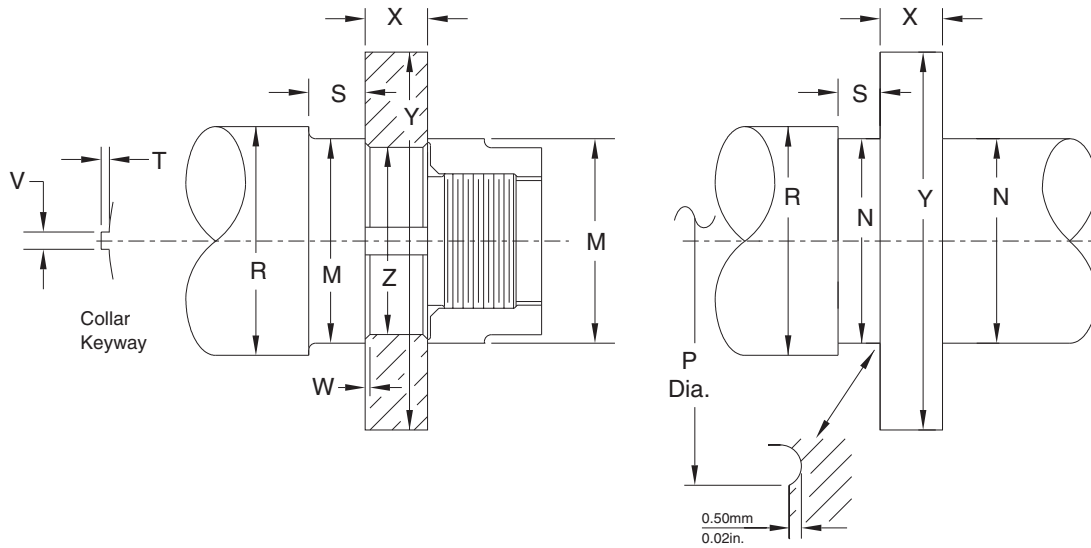

Bearing Size	13.5	15	17	19	21	23	25	27
No. of Shoes 6 for J&B 8 for E								
Area (in <sup>2</sup> )	91.1	112.5	144.5	180.5	220.5	264.5	312.5	364.5
A – Babbitt O.D.	13.50	15.00	17.00	19.00	21.00	23.00	25.00	27.00
B – Babbitt I.D.	6.75	7.50	8.50	9.50	10.50	11.50	12.50	13.50
H – Bearing Height (J)	4.25	4.62	5.25	—	—	—	—	—
H – Bearing Height (B)	3.56	3.88	4.38	4.75	5.25	5.69	6.19	6.69
C – Bearing O.D.	14.000	15.500	17.625	20.250	22.250	24.500	26.500	28.750
Q – Base ring I.D.	7.31	8.12	9.19	10.62	11.75	12.75	14.00	15.75
D – Oil annulus dia.	13.00	14.50	16.50	18.50	20.25	22.38	24.50	26.50
E – Oil annulus depth (J)	1.44	1.38	1.81	—	—	—	—	—
E – Oil annulus depth (B)	0.75	0.63	0.94	0.88	1.00	1.00	1.12	1.19
F – Bearing key, length	1.38	1.50	1.62	1.75	1.75	2.12	2.25	2.38
G – Bearing key, width	0.62	0.69	0.75	0.88	1.00	1.00	1.25	1.25
J – Collar to key	0.75	0.81	0.94	1.00	1.12	1.31	1.38	1.44
K – Key projection	0.25	0.31	0.31	0.34	0.38	0.38	0.50	0.50
M – Separate shaft dia.	6.38	7.00	8.00	8.88	9.88	10.75	11.75	12.62
N – Integral shaft dia.	6.25	6.88	7.88	8.75	9.75	10.50	11.50	12.25
P – Max dia. over fillet	6.62	7.32	8.32	9.27	10.27	11.17	12.17	13.07
R – Dia. through base ring	6.75	7.50	8.50	9.75	10.75	11.75	12.88	13.88
S – Shaft lgth @ shoe I.D.	1.50	1.62	1.75	2.00	2.25	2.38	2.50	2.75
X – Collar thickness	2.25	2.50	2.88	3.25	3.62	3.88	4.25	4.62
Y – Collar dia.	13.69	15.19	17.25	19.25	21.25	23.25	25.25	27.25
Z – Collar bore	5.375	6.000	6.625	7.500	8.500	9.375	10.000	11.000
T – Collar key depth	0.44	0.50	0.50	0.56	0.62	0.62	0.75	0.75
V – Collar key width	0.88	1.00	1.00	1.12	1.25	1.25	1.50	1.50
W – Collar chamfer	0.09	0.09	0.12	0.12	0.12	0.16	0.16	0.16
DD – Straddle mill	4.22	5.09	5.72	5.97	6.97	7.69	8.00	8.31
EE – Shoe thickness	1.500	1.625	1.812	2.000	2.188	2.375	2.688	2.750
FF – Shoe relief	0.38	0.12	0.12	0.38	0.50	0.50	0.50	0.50
Weight (Lbs) Bearing	90.9	123.7	176	237	312	406	506	643
Weight (Lbs) Collar	79	108	162	228	308	394	514	645
Weight (Lbs) Spare shoes	34.5	47	68	100	132	168	221	264

## RATED LOAD FOR STYLE J, B, AND E THRUST BEARINGS (ENGLISH)

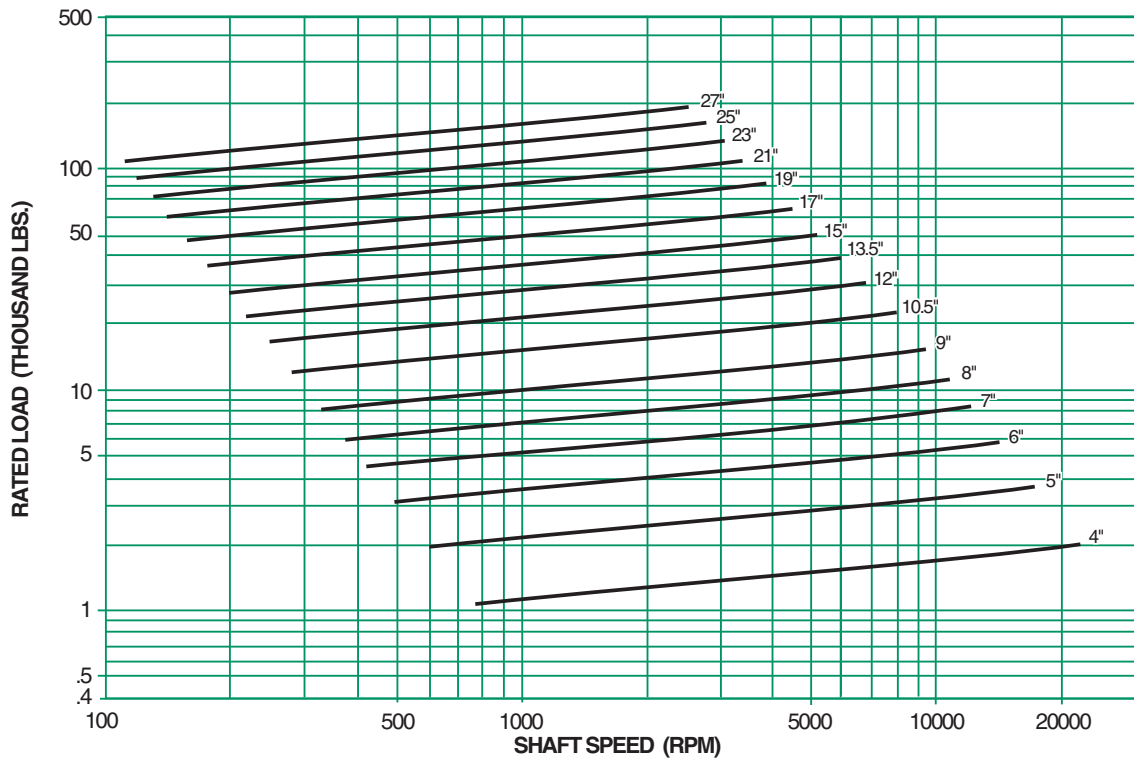

Based on ISO VG 32 supplied at 120°F.

## RECOMMENDED OIL SUPPLY FOR J, B, AND E THRUST BEARINGS (ENGLISH)

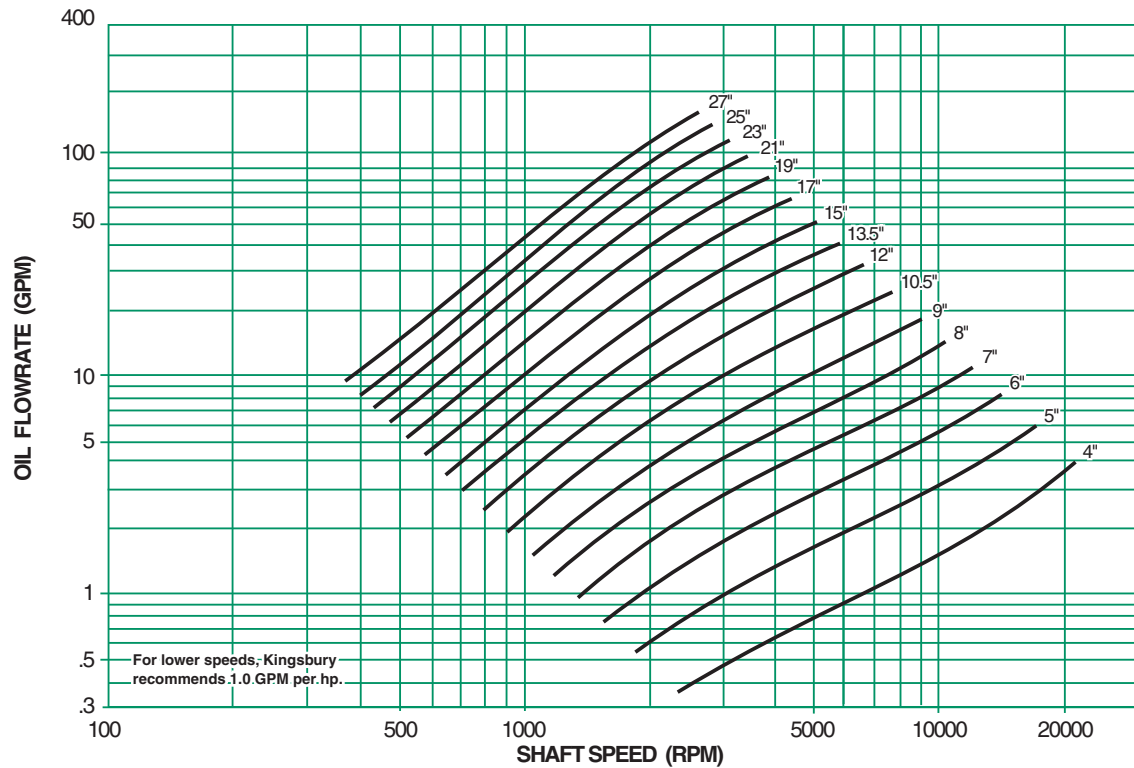

For lower speeds, Kingsbury recommends 1.0 GPM per hp.

Based on 20% Slack Flow & ISO VG 32 supplied at 120°F.

This chart gives loaded side, single element flowrates for rated load. For double element bearings, supply an additional 20% to the inactive side. In machines where load may reverse and apply rated values to either side, provide equal flow to each side (a total of two times the chart value).



**POWER LOSS FOR DOUBLE ELEMENT STYLE J, B, AND E THRUST BEARINGS (ENGLISH)**

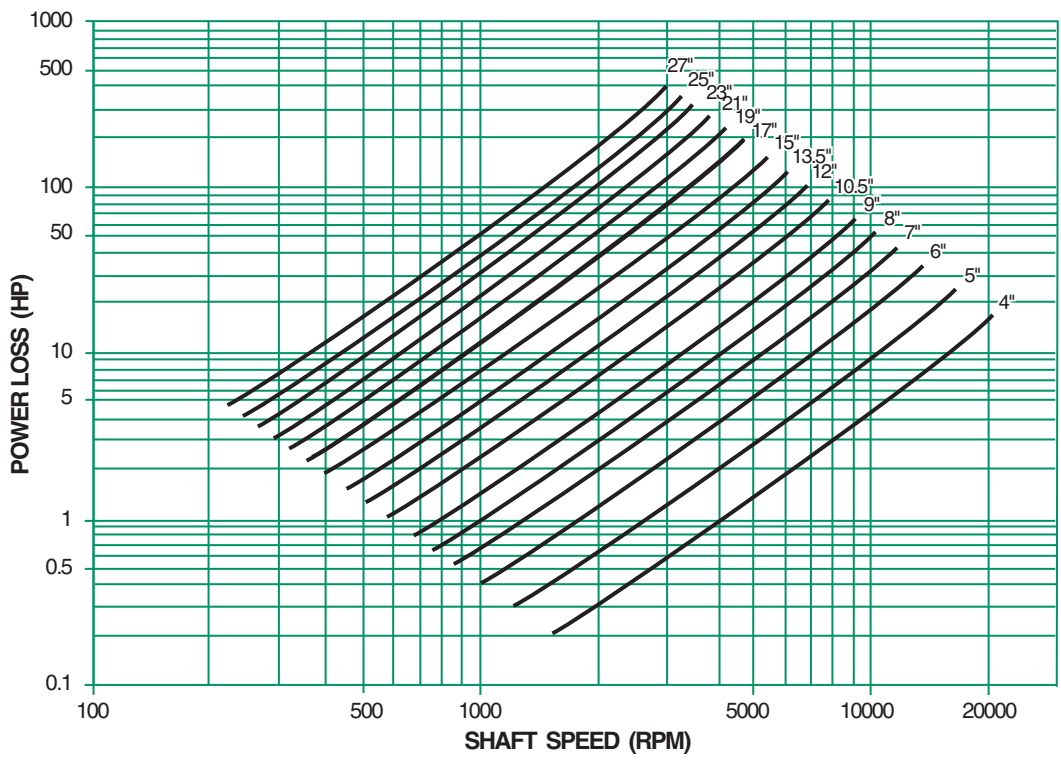

**POWER LOSS FOR SINGLE ELEMENT STYLE J, B, AND E THRUST BEARINGS (ENGLISH)**

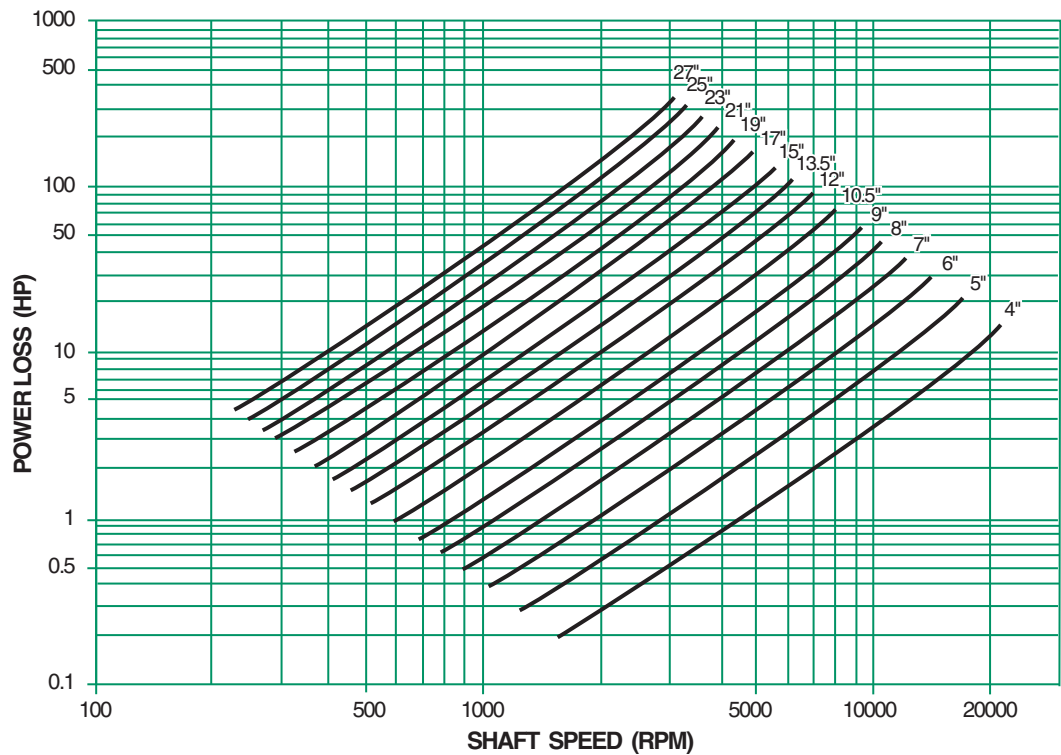

Based on 20% Slack Flow & ISO VG 32 supplied at 120°F.  
 Power loss is based on rated load, recommended oil flow, and Kingsbury's recommended discharge configuration.  
 If any of these is changed, the power loss will also change.

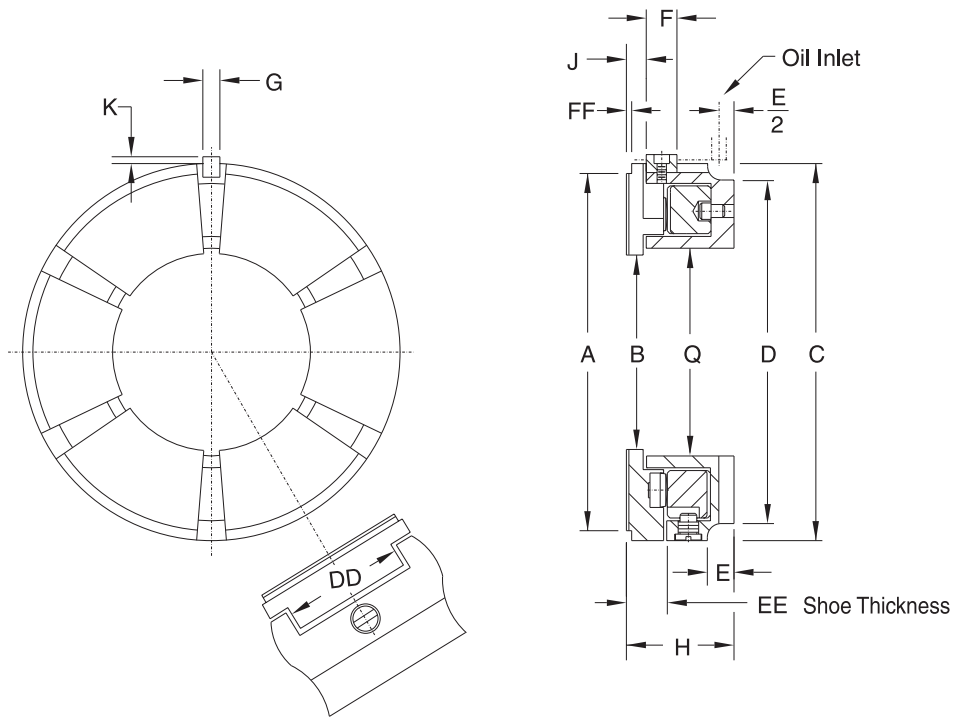

### Style J, B, E Bearings—Metric Conversion (mm)

Bearing Size (inches)	4	5	6	7	8	9	10.5	12
No. of Shoes 6 for J&B 8 for E								
Area (mm <sup>2</sup> )	5160	8065	11615	15805	20260	26130	35550	46450
A – Babbitt O.D.	101.6	127.0	152.4	177.8	203.2	228.06	266.7	304.8
B – Babbitt I.D.	50.8	63.5	76.2	88.9	104.6	114.03	133.35	152.4
H – Bearing Height (J)	36.6	44.5	52.3	60.5	68.3	76.2	85.9	95.3
H – Bearing Height (B)	35.1	41.2	47.8	53.9	60.5	68.3	74.7	82.6
C – Bearing O.D.	111.12	136.52	161.92	187.32	212.72	238.12	279.40	317.50
Q – Base ring I.D.	55.6	69.9	82.6	95.3	109.5	124.0	144.5	165.1
D – Oil annulus dia.	104.7	125.5	150.9	171.5	193.6	219.0	254.0	293.6
E – Oil annulus depth (J)	9.7	12.7	15.0	17.5	20.8	22.4	25.4	30.2
E – Oil annulus depth (B)	7.9	9.7	10.2	11.2	13.0	14.5	14.2	17.5
F – Bearing key, length	9.7	14.2	16.8	20.6	23.9	23.9	28.5	30.2
G – Bearing key, width	6.4	7.9	9.7	9.7	11.2	11.2	12.7	14.2
J – Collar to key	7.1	7.9	9.7	11.9	12.7	14.2	15.8	17.5
K – Key projection	3.1	4.1	4.8	4.8	4.8	4.8	5.6	5.6
M – Separate shaft dia.	44.5	57.2	69.9	82.6	95.3	108.0	124.0	142.8
N – Integral shaft dia.	41.2	53.8	66.6	79.3	92.0	104.7	120.7	139.7
P – Max dia. over fillet	46.5	61.3	74.0	86.8	99.3	112.2	130.0	149.1
R – Dia. through base ring	49.3	63.5	76.2	88.9	101.6	114.3	133.4	152.4
S – Shaft lgth @ shoe I.D.	12.7	15.8	19.1	22.4	25.4	28.5	31.8	35.1
X – Collar thickness	22.4	22.4	25.4	31.8	35.1	38.1	44.5	50.8
Y – Collar dia.	104.7	130.1	155.5	180.8	206.3	231.7	271.5	309.6
Z – Collar bore	31.75	44.45	53.98	63.50	76.20	88.90	104.78	120.65
T – Collar key depth	4.1	4.8	4.8	6.4	7.9	7.9	9.7	9.7
V – Collar key width	7.9	9.7	9.7	12.7	15.8	15.8	19.1	19.1
W – Collar chamfer	1.5	1.5	1.5	1.5	1.5	1.5	2.3	2.3
DD – Straddle mill	32.5	40.5	50.0	59.5	69.1	77.0	80.9	100.8
EE – Shoe thickness	12.70	15.88	19.05	22.23	25.40	28.58	31.75	34.93
FF – Shoe relief	3.1	4.1	4.1	4.8	5.6	7.9	7.1	8.6
Weight (kg) Bearing	1.6	2.6	4.1	6.7	9.5	13.8	20.4	29.2
Weight (kg) Collar	1.4	2.1	3.4	5.7	7.9	10.7	17.1	25.4
Weight (kg) Spare shoes	0.5	1.0	1.6	2.5	3.5	5.1	8.2	11.3

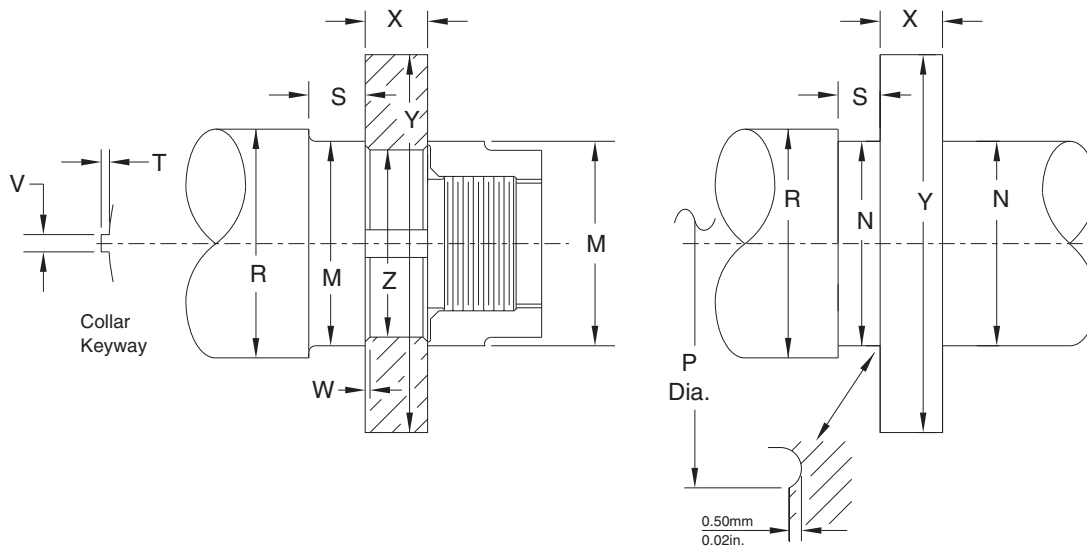

Bearing Size (inches)	13.5	15	17	19	21	23	25	27
No. of Shoes 6 for J&B 8 for E								
Area (mm <sup>2</sup> )	58775	72580	93225	116450	142260	170645	201610	235160
A – Babbitt O.D.	342.9	381.0	431.8	482.6	533.4	584.2	635.0	685.8
B – Babbitt I.D.	171.45	190.5	215.9	241.3	266.7	292.1	317.5	342.9
H – Bearing Height (J)	108.0	117.4	133.4					
H – Bearing Height (B)	90.4	98.6	111.3	120.7	133.4	144.5	157.2	169.9
C – Bearing O.D.	355.60	393.70	447.68	514.35	565.15	622.30	673.10	730.25
Q – Base ring I.D.	185.7	206.3	233.4	269.8	298.5	323.9	355.60	400.0
D – Oil annulus dia.	330.2	368.3	419.1	469.9	514.4	568.5	622.3	673.1
E – Oil annulus depth (J)	36.6	35.1	46.0	—	—	—	—	—
E – Oil annulus depth (B)	19.1	16.0	23.9	22.4	25.4	25.4	28.5	30.2
F – Bearing key, length	35.1	38.1	41.2	44.5	44.5	53.9	57.2	60.5
G – Bearing key, width	15.8	17.5	19.1	22.4	25.4	25.4	31.8	31.8
J – Collar to key	19.1	20.6	23.9	25.4	28.5	33.3	35.1	36.6
K – Key projection	6.4	7.9	7.9	8.6	9.7	9.7	12.7	12.7
M – Separate shaft dia.	162.1	177.8	203.2	225.6	251.0	273.1	298.5	320.6
N – Integral shaft dia.	158.8	174.8	200.2	222.3	247.7	266.7	292.1	311.2
P – Max dia. over fillet	168.1	186.0	211.3	235.6	261.0	283.7	309.2	332.0
R – Dia. through base ring	171.5	190.5	215.9	247.7	273.1	298.5	327.2	352.6
S – Shaft lgth @ shoe I.D.	38.1	41.2	44.5	50.8	57.2	60.5	63.5	69.9
X – Collar thickness	57.2	63.5	73.2	82.6	92.0	98.6	108.0	117.4
Y – Collar dia.	347.7	385.8	438.2	489.0	539.8	590.6	641.4	692.2
Z – Collar bore	136.53	152.40	168.28	190.50	215.90	238.13	254.00	279.40
T – Collar key depth	11.2	12.7	12.7	14.2	15.8	15.8	19.1	19.1
V – Collar key width	22.4	25.4	25.4	28.5	31.8	31.8	38.1	38.1
W – Collar chamfer	2.3	2.3	3.1	3.1	3.1	4.1	4.1	4.1
DD – Straddle mill	107.2	129.4	145.3	151.6	177.0	195.3	203.2	211.1
EE – Shoe thickness	38.10	41.28	46.03	50.80	55.58	60.33	68.28	69.85
FF – Shoe relief	9.7	3.1	3.1	9.7	12.7	12.7	12.7	12.7
Weight (kg) Bearing	41.2	56.1	80.0	107.5	141.5	184.2	229.5	292.0
Weight (kg) Collar	35.8	49.0	73.5	103.4	139.7	178.7	233.1	292.6
Weight (kg) Spare shoes	15.6	21.3	30.8	45.4	59.9	76.2	100.2	120.0

## RATED LOAD FOR STYLE J, B, AND E THRUST BEARINGS (METRIC)

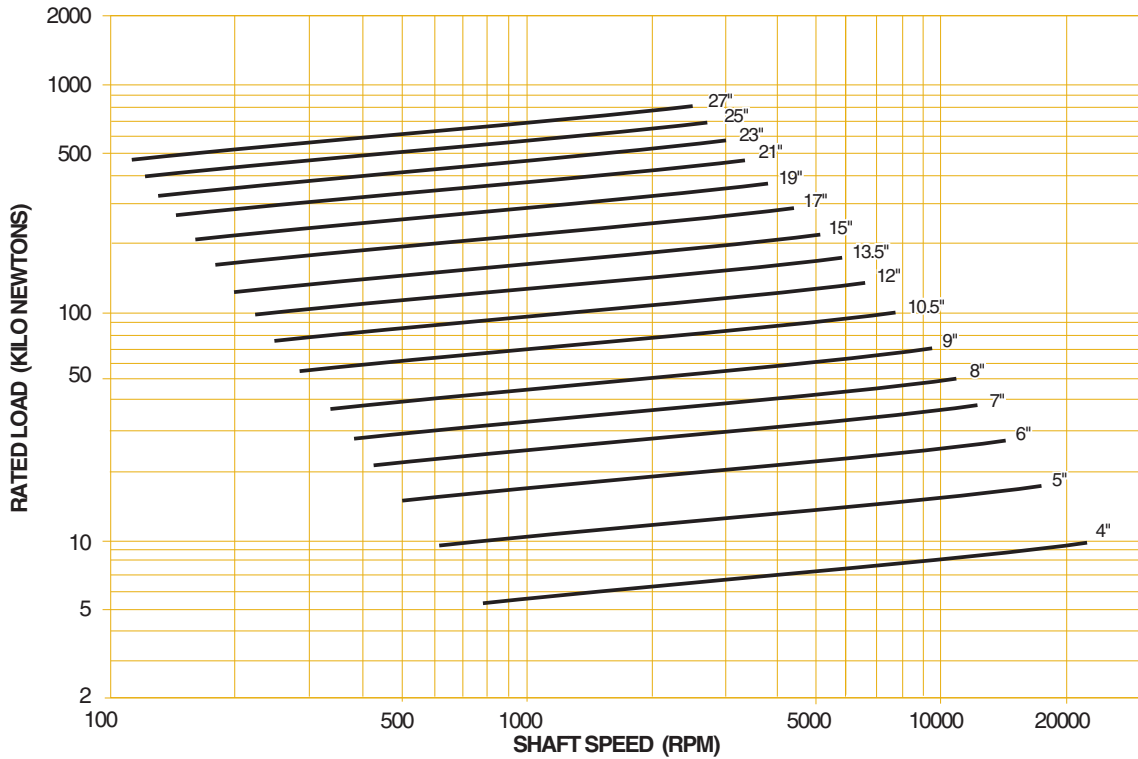

Based on ISO VG 32 supplied at 50°C.

## RECOMMENDED OIL SUPPLY FOR J, B, AND E THRUST BEARINGS (METRIC)

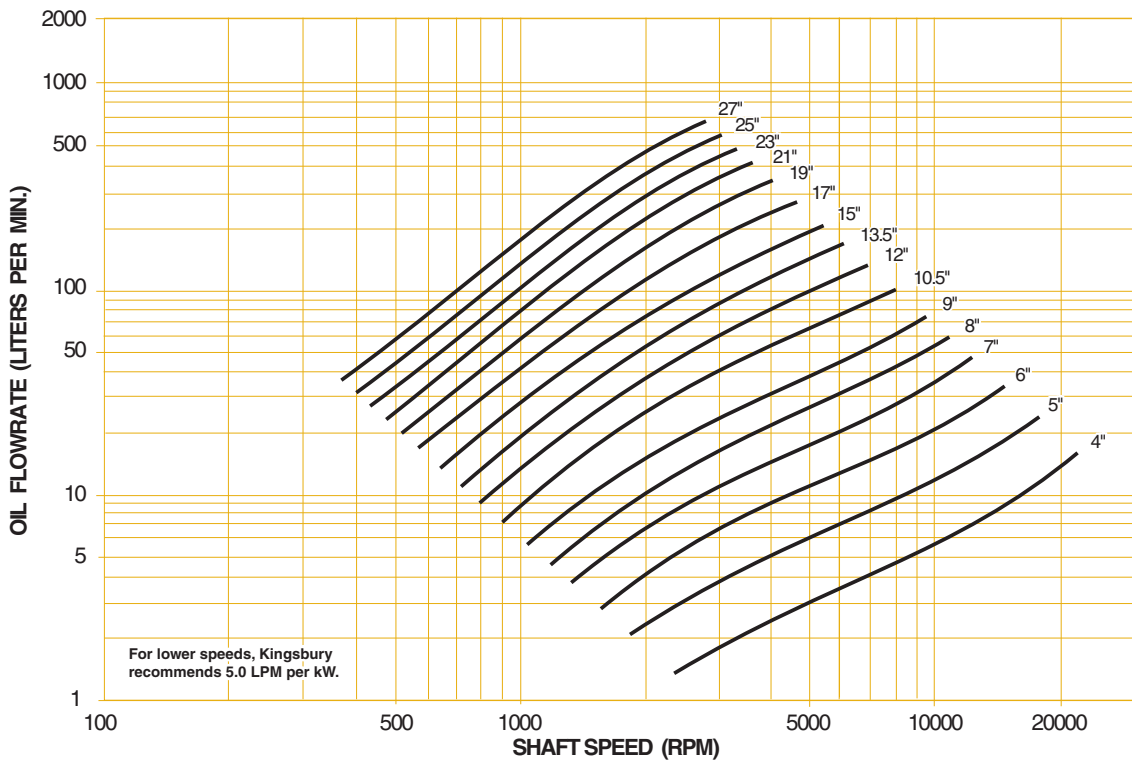

Based on 20% Slack Flow & ISO VG 32 supplied at 50°C.

This chart gives loaded side, single element flowrates for rated load. For double element bearings, supply an additional 20% to the inactive side. In machines where load may reverse and apply rated values to either side, provide equal flow to each side (a total of two times the chart value).

**POWER LOSS FOR DOUBLE ELEMENT STYLE J, B, AND E THRUST BEARINGS (METRIC)**

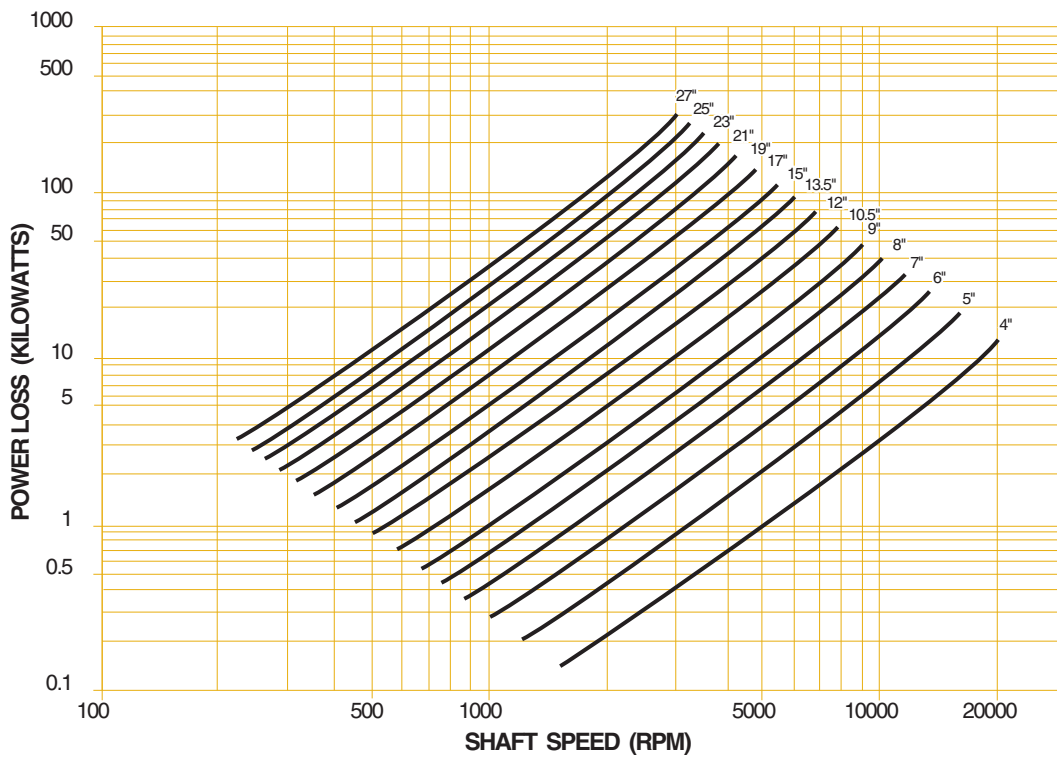

**POWER LOSS FOR SINGLE ELEMENT STYLE J, B, AND E THRUST BEARINGS (METRIC)**

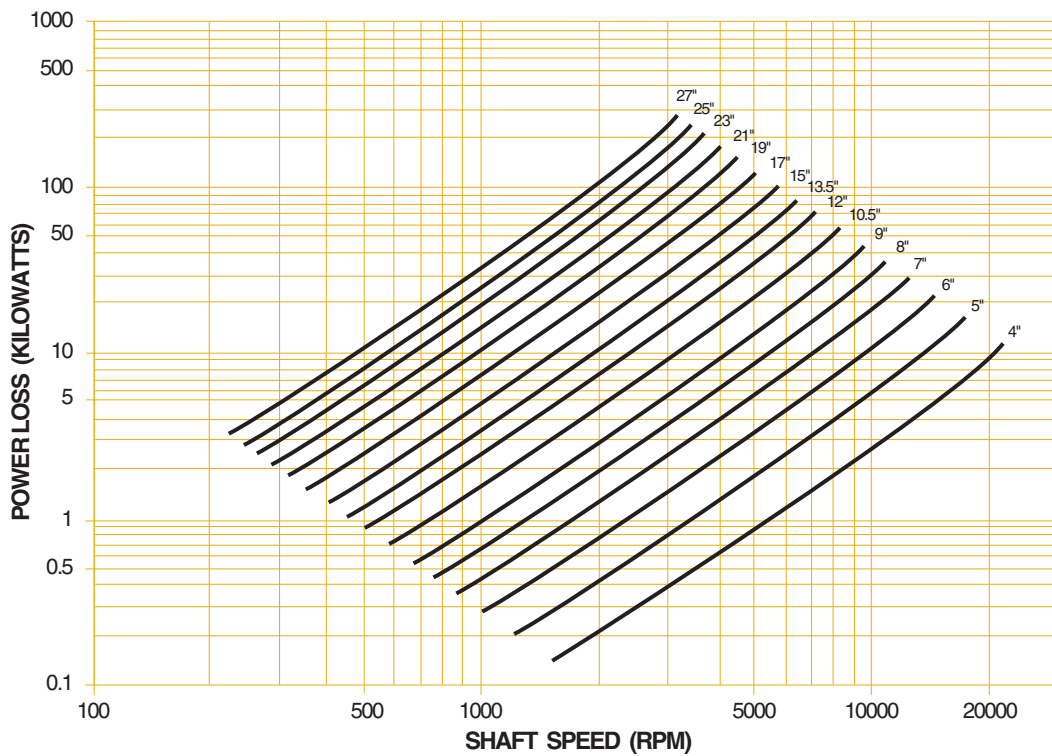

Based on 20% Slack Flow & ISO VG 32 supplied at 50°C.  
 Power loss is based on rated load, recommended oil flow, and Kingsbury's recommended discharge configuration.  
 If any of these is changed the power loss will also change.

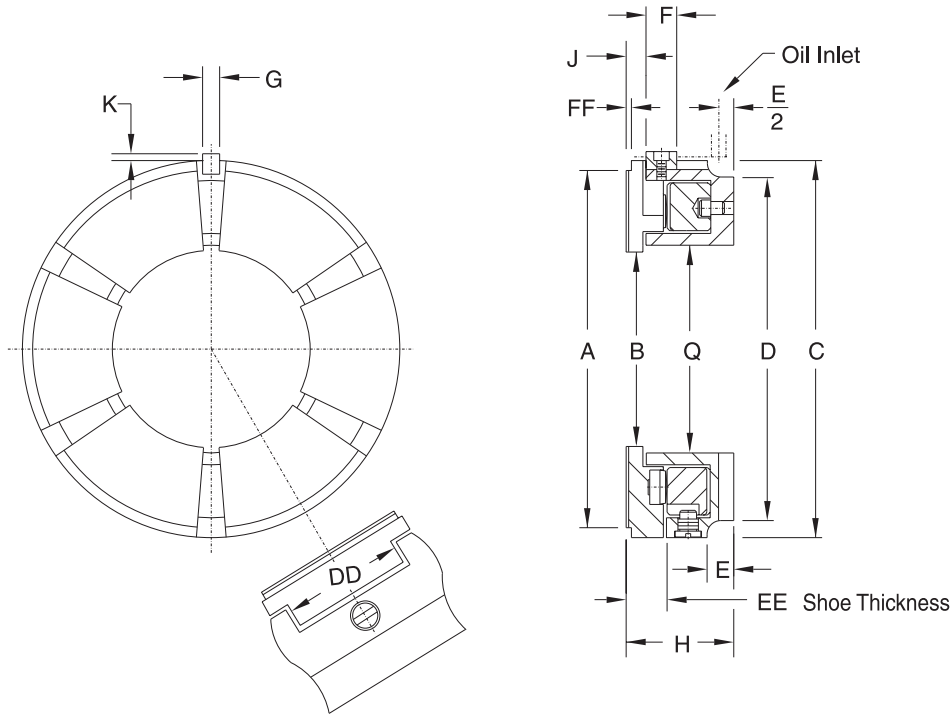

### Style S Bearings—English Units (inches), Sizes 3" through 26.5"

Bearing Size	3	4	5	6.5	7.5	8	9.88	11.12	12.25
Number of Shoes	4	4	8	8	8	8	12	8	8
Area (in <sup>2</sup> )	3.5	6	8.5	15.5	21	20	34	54	54
A – Babbitt O.D.	3.00	4.00	5.00	6.50	7.50	8.00	9.88	11.12	12.25
B – Babbitt I.D.	1.25	1.75	3.25	4.06	4.62	5.50	7.00	6.50	7.50
H – Bearing Height	1.25	1.62	1.56	1.56	2.00	1.94	1.88	2.75	2.31
C – Bearing O.D.	3.250	4.875	5.375	6.750	7.750	8.375	10.125	11.500	12.625
Q – Base ring I.D.	1.50	1.75	3.25	4.06	4.75	5.50	7.00	6.75	7.62
D – Oil annulus dia.	3.00	4.00	5.00	6.38	7.31	7.81	9.69	10.88	11.62
E – Oil annulus depth, min.	0.25	0.44	0.41	0.41	0.50	0.53	0.50	0.62	0.44
F – Bearing key, length	0.16	0.56	0.25	0.56	0.66	0.75	0.66	0.94	0.94
G – Bearing key, width	0.16	0.31	0.31	0.31	0.38	0.50	0.38	0.44	0.44
J – Collar to key	0.50	0.59	0.50	0.31	0.44	0.44	0.31	0.59	0.59
K – Key projection	0.16	0.16	0.12	0.16	0.19	0.19	0.19	0.19	0.19
M – Separate shaft dia.	1.12	1.44	3.00	3.88	4.38	5.25	6.62	6.12	7.12
N – Integral shaft dia.	1.00	1.25	2.75	3.62	4.12	5.00	6.25	5.88	7.00
P – Max dia. over fillet	1.12	1.56	3.00	3.88	4.44	5.31	6.81	6.31	7.38
R – Dia. through base ring	1.25	1.44	3.00	3.88	4.38	5.25	6.62	6.12	7.25
S – Shaft lgth @ shoe I.D.	0.44	–	–	–	–	–	–	0.62	1.12
X – Collar thickness	0.62	0.88	0.88	1.00	1.12	1.38	1.50	1.75	2.00
Y – Collar dia.	3.12	4.62	5.12	6.62	7.62	8.12	10.00	11.25	12.38
Z – Collar bore	0.875	1.125	2.800	3.500	4.125	4.500	6.000	5.500	6.500
T – Collar key depth	0.06	0.16	0.16	0.19	0.19	0.31	0.19	0.31	0.38
V – Collar key width	0.12	0.31	0.31	0.38	0.38	0.62	0.38	0.62	0.75
W – Collar chamfer	0.02	0.02	0.02	0.02	0.02	0.06	0.06	0.09	0.09
DD – Straddle mill	1.25	–	1.22	1.59	1.97	2.13	1.72	2.84	3.03
EE – Shoe thickness	0.438	0.562	0.498	0.562	0.781	0.687	0.781	1.125	1.125
FF – Shoe relief	0.12	0.28	0.12	0.19	0.12	–	0.13	0.19	0.31
Weight (Lbs) Bearing	1.6	5.5	5.0	8.0	13	16	25	45	48
Weight (Lbs) Collar	1.25	4.0	4.5	7.0	10.5	14	21	37	50
Weight (Lbs) Spare shoes	0.4	1.2	1.2	2.4	4.5	3	7	16	16

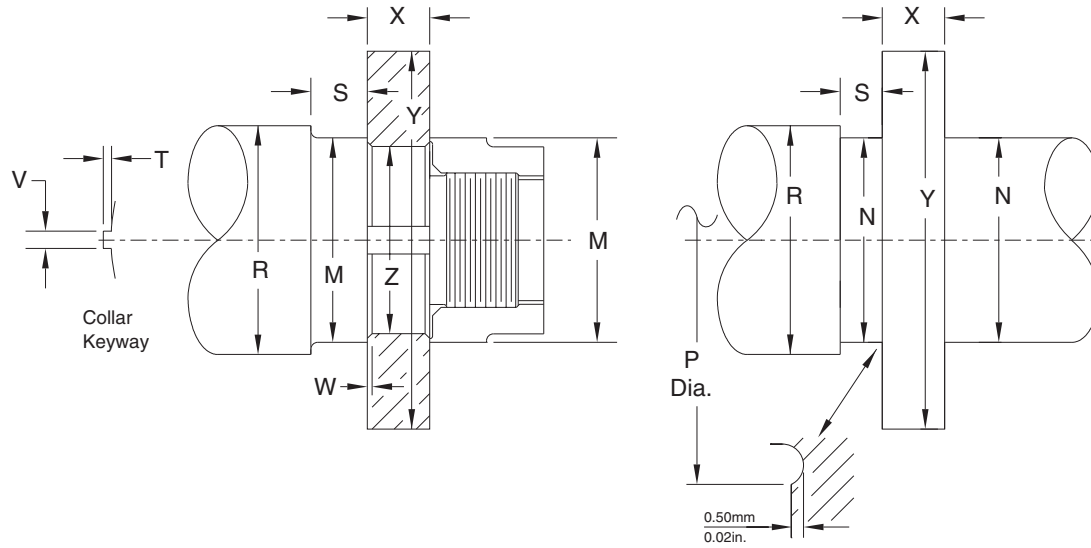

Bearing Size	13	15	18	22	22.5-A	22.5-B	25-A	25-B	26.00	26.5
Number of Shoes	8	10	8	10	8	8	8	8	8	8
Area (in <sup>2</sup> )	73.5	70	91	92	152	230	265	172	160	273
A – Babbitt O.D.	13.00	15.00	18.00	22.00	22.50	22.50	25.00	25.00	26.00	26.50
B – Babbitt I.D.	7.75	10.50	12.25	16.25	14.00	13.00	15.00	17.00	18.00	17.00
H – Bearing Height	2.81	2.75	3.50	3.00	5.00	5.00	6.12	4.75	4.75	5.75
C – Bearing O.D.	13.500	15.500	18.750	22.500	23.125	23.125	26.500	26.000	26.750	27.000
Q – Base ring I.D.	8.12	10.62	12.75	16.75	14.00	14.00	15.62	16.25	18.00	17.00
D – Oil annulus dia.	12.88	14.88	17.88	21.62	22.12	22.12	24.75	25.19	25.31	25.19
E – Oil annulus depth, min.	0.75	0.69	0.88	0.75	1.25	1.25	1.19	1.75	1.69	2.38
F – Bearing key, length	0.94	0.94	1.19	1.19	1.62	1.62	2.50	1.38	1.38	2.12
G – Bearing key, width	0.44	0.44	0.56	0.56	0.75	0.75	1.12	1.00	1.00	1.12
J – Collar to key	0.66	1.12	0.75	0.66	1.12	1.12	2.50	1.00	1.00	1.12
K – Key projection	0.19	0.19	0.22	0.25	0.38	0.38	0.50	0.44	0.44	0.50
M – Separate shaft dia.	7.50	10.25	11.88	16.00	13.50	12.50	14.50	16.00	17.38	16.38
N – Integral shaft dia.	7.12	9.75	11.50	15.50	13.00	12.00	14.00	16.00	17.00	16.00
P – Max dia. over fillet	7.56	10.25	12.00	16.00	13.62	12.62	14.62	16.62	17.62	16.62
R – Dia. through base ring	7.75	10.25	12.38	16.00	13.50	13.50	15.12	18.00	17.88	17.75
S – Shaft lgth @ shoe I.D.	1.25	1.12	1.44	1.25	1.94	1.94	2.12	3.50	2.75	2.00
X – Collar thickness	2.25	2.50	3.00	2.00	3.25	3.25	4.25	4.25	4.50	4.00
Y – Collar dia.	13.19	15.19	18.25	22.25	22.75	22.75	25.25	25.25	26.25	26.75
Z – Collar bore	6.750	9.000	10.500	14.750	12.250	11.250	13.000	15.250	15.875	14.750
T – Collar key depth	0.38	0.50	0.50	0.38	0.62	0.62	0.75	0.75	0.75	0.75
V – Collar key width	0.75	1.00	1.00	0.75	1.25	1.25	1.50	1.50	1.50	1.50
W – Collar chamfer	0.09	0.09	0.12	0.31	0.16	0.16	0.16	0.16	0.16	0.16
DD – Straddle mill	3.19	3.19	4.09	3.19	4.97	4.97	6.97	5.00	5.25	6.50
EE – Shoe thickness	1.250	1.125	1.438	1.250	1.938	1.938	2.125	1.750	1.781	2.000
FF – Shoe relief	0.16	0.28	0.31	0.28	0.56	0.56	0.38	0.38	0.38	0.25
Weight (Lbs) Bearing	57	65	115	112	286	321	492	310	298	395
Weight (Lbs) Collar	64	84	135	122	265	282	440	380	435	440
Weight (Lbs) Spare shoes	25	21	35	30	78	112	157	88	77	152

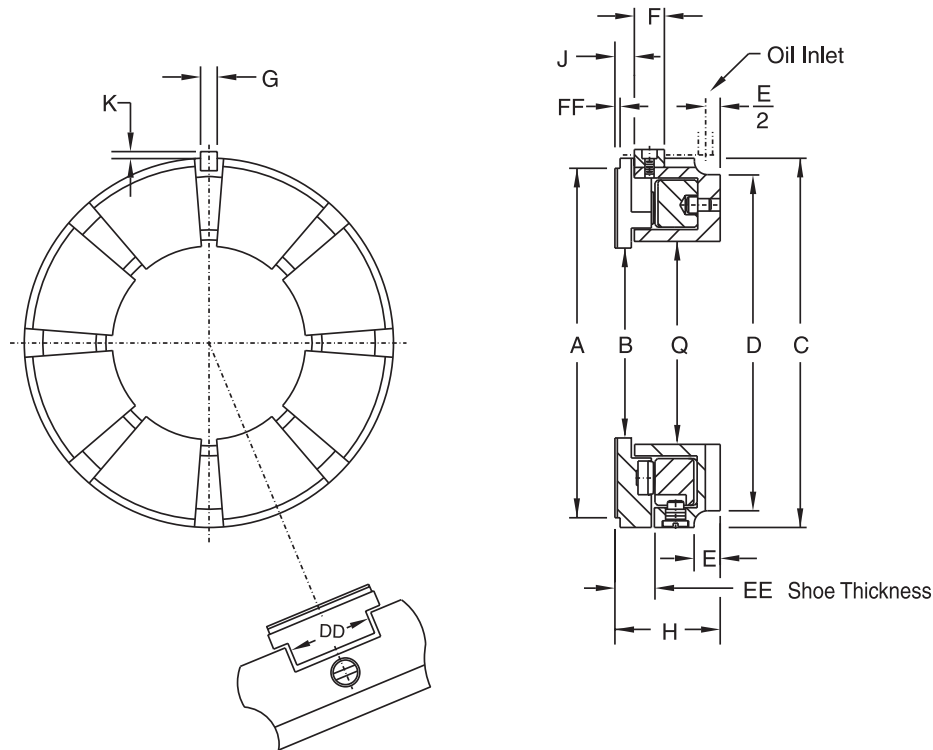

### Style S Bearings—English units (inches), Sizes 27" – 72"

Bearing Size	27	29.5	30-A	30-B	30.5	31	31.5	35
Number of Shoes	8	8	18	8	8	8	20	8
Area (in <sup>2</sup> )	332.5	396	222	274	401	470	207	603
A – Babbitt O.D.	27.00	29.50	30.00	30.00	30.50	31.00	31.50	35.00
B – Babbitt I.D.	15.50	17.00	24.00	19.00	18.50	16.50	26.00	18.50
H – Bearing Height	5.75	6.38	3.50	5.00	5.00	6.38	4.00	6.75
C – Bearing O.D.	27.750	30.250	30.000	30.750	30.750	31.750	32.000	35.750
Q – Base ring I.D.	15.50	17.00	24.25	19.50	19.50	17.00	26.00	19.31
D – Oil annulus dia.	26.12	28.75	28.85	28.75	28.75	28.75	31.00	32.88
E – Oil annulus depth, min.	1.94	2.44	1.06	2.25	1.62	2.44	1.50	2.00
F – Bearing key, length	2.25	1.88	1.19	1.62	1.62	1.88	1.19	2.25
G – Bearing key, width	1.25	1.25	0.56	1.00	1.00	1.25	0.56	1.25
J – Collar to key	1.25	1.38	0.75	1.12	1.12	1.38	0.88	1.62
K – Key projection	0.50	0.50	0.31	0.44	0.44	0.50	0.31	0.50
M – Separate shaft dia.	14.75	16.50	23.00	18.00	18.00	16.00	25.00	18.00
N – Integral shaft dia.	14.12	16.00	22.38	17.38	16.88	14.88	25.00	17.00
P – Max dia. over fillet	15.00	16.62	23.38	18.38	17.88	15.88	25.62	18.00
R – Dia. through base ring	16.50	19.00	23.62	20.25	20.25	18.75	25.25	21.25
S – Shaft lgth @ shoe I.D.	3.25	3.88	1.38	3.00	3.00	3.88	1.50	4.12
X – Collar thickness	4.50	5.00	2.50	5.12	5.25	5.25	5.25	6.00
Y – Collar dia.	27.25	29.75	30.12	30.25	30.62	31.25	31.75	35.25
Z – Collar bore	13.500	14.750	21.000	16.500	16.250	14.250	23.000	15.750
T – Collar key depth	0.75	0.88	0.62	0.88	0.88	0.88	0.88	1.00
V – Collar key width	1.50	1.75	1.25	1.75	1.75	1.75	1.75	2.00
W – Collar chamfer	0.16	0.19	0.12	0.19	0.19	0.19	0.19	0.25
DD – Straddle mill	6.59	7.25	3.91	5.75	7.75	7.75	3.75	8.25
EE – Shoe thickness	2.125	2.625	1.375	2.000	2.000	2.656	1.500	3.00
FF – Shoe relief	0.38	0.50	–	0.50	0.44	0.50	0.19	0.50
Weight (Lbs) Bearing	552	685	248	430	478	720	240	1000
Weight (Lbs) Collar	560	740	260	730	780	900	570	1300
Weight (Lbs) Spare shoes	195	260	77	136	184	336	80	445



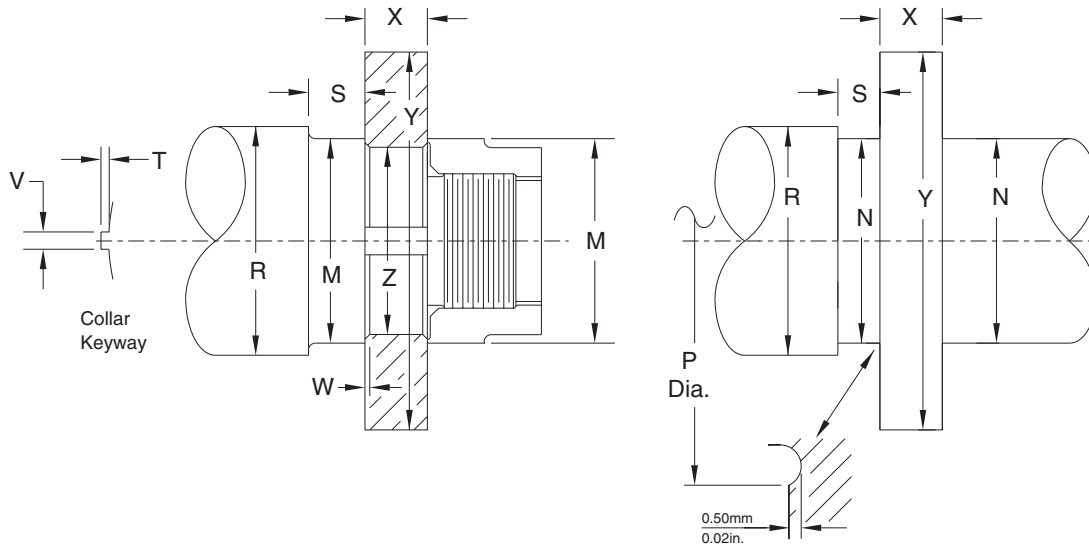

Bearing Size	39	41	43	45	46	50	54	61	65	72
Number of Shoes	8	8	8	8	8	8	8	8	8	8
Area (in <sup>2</sup> )	794	935.5	811.5	1015	937.5	1174.5	1337	1895.5	2342	2480
A – Babbitt O.D.	39.00	41.00	43.00	45.00	46.00	50.00	54.00	61.00	65.00	72.00
B – Babbitt I.D.	18.00	18.00	25.00	23.50	26.50	27.00	30.00	30.00	28.00	38.00
H – Bearing Height	7.25	7.25	8.50	9.00	9.00	10.00	10.63	11.13	12.56	14.50
C – Bearing O.D.	41.250	42.500	44.000	46.000	47.000	50.750	54.750	61.750	65.750	73.000
Q – Base ring I.D.	20.25	20.25	26.00	27.63	26.75	30.00	31.50	33.75	31.00	40.00
D – Oil annulus dia.	36.75	36.75	41.75	44.00	44.00	48.25	51.75	56.75	61.75	69.00
E – Oil annulus depth, min.	1.69	1.69	2.00	3.88	3.75	3.25	4.25	4.00	4.44	5.00
F – Bearing key, length	3.25	3.25	2.75	1.75	1.75	3.00	2.00	2.00	5.00	5.00
G – Bearing key, width	1.75	1.75	1.75	1.75	1.75	2.00	2.00	2.00	2.75	2.75
J – Collar to key	1.88	1.88	2.06	3.00	3.00	3.25	3.25	3.75	3.13	3.88
K – Key projection	.63	.63	.63	1.25	1.25	.75	1.00	1.00	1.50	1.38
M – Separate shaft dia.	15.75	15.75	23.75	22.25	25.25	25.50	28.50	28.50	26.25	36.25
N – Integral shaft dia.	14.88	14.88	22.75	21.25	24.00	24.50	27.50	27.50	25.25	35.25
P – Max dia. over fillet	17.13	17.13	24.13	23.50	25.50	26.00	29.00	29.00	27.00	37.00
R – Dia. through base ring	23.00	23.65	27.00	25.50	28.75	31.50	33.75	37.00	34.75	44.00
S – Shaft lgth @ shoe I.D.	4.50	4.50	5.00	5.50	5.00	6.00	6.63	7.00	7.50	8.75
X – Collar thickness	7.00	7.00	7.25	7.63	7.63	9.00	9.50	10.50	11.00	11.50
Y – Collar dia.	39.50	42.00	43.50	45.50	46.50	50.50	54.50	61.50	65.50	72.75
Z – Collar bore	14.000	14.000	22.000	20.750	23.250	23.500	26.500	26.500	24.250	34.250
T – Collar key depth	1.13	1.13	1.13	1.13	1.13	1.25	1.25	1.38	1.38	1.50
V – Collar key width	2.25	2.25	2.25	2.25	2.25	2.50	2.50	2.75	2.75	2.75
W – Collar chamfer	.38	.38	.38	.38	.38	.50	.50	.63	.63	.75
DD – Straddle mill	9.19	9.19	11.09	11.09	11.97	12.94	14.94	16.69	17.69	16.88
EE – Shoe thickness	3.929	3.312	3.625	3.625	3.750	4.250	4.500	5.000	5.500	6.125
FF – Shoe relief	1.11	.11	.24	.49	.24	.24	.37	.36	.49	.61
Weight (Lbs) Bearing	1650	1800	2075	2100	2300	2900	3700	5200	7500	9500
Weight (Lbs) Collar	2045	2165	2760	2780	2750	4000	4800	7200	9100	10500
Weight (Lbs) Spare shoes	666	720	700	830	820	1130	1380	2100	3000	3400

## RATED LOAD FOR STYLE S THRUST BEARINGS (ENGLISH)

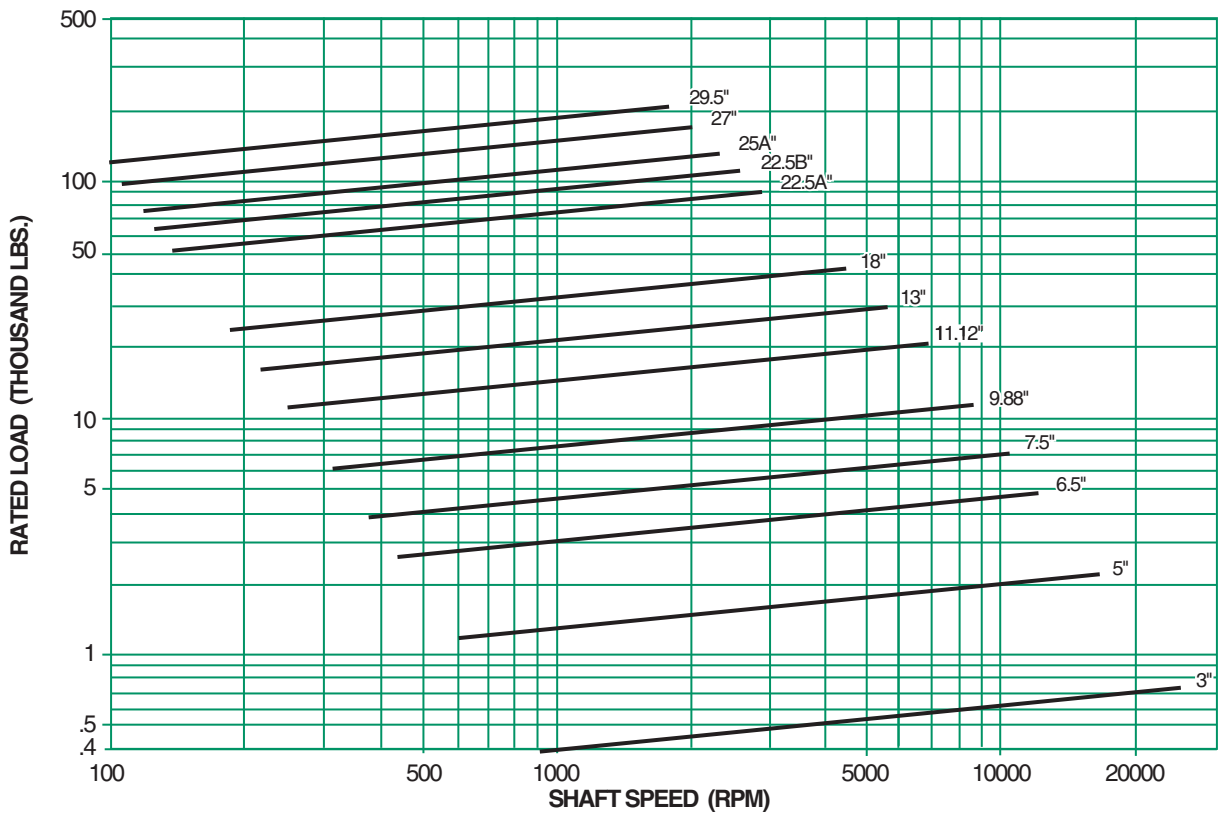
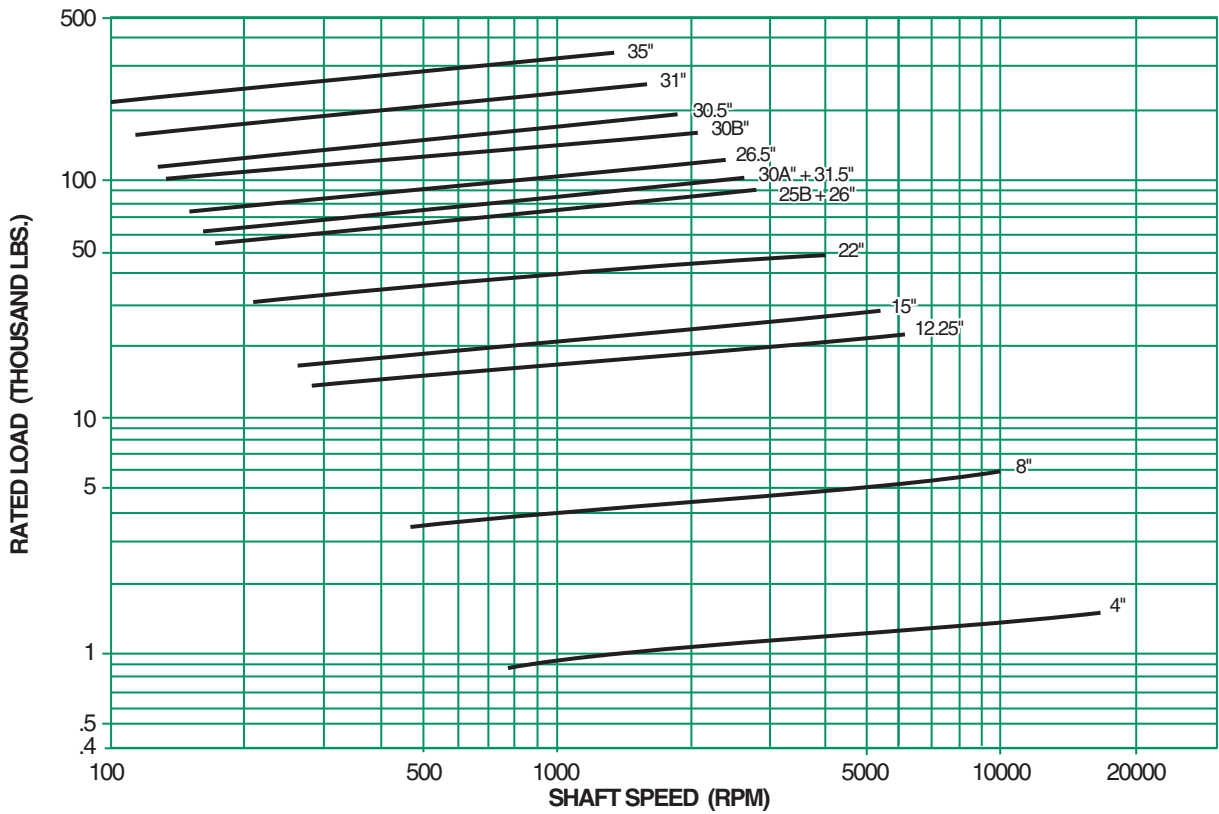

Based on ISO VG 32 supplied at 120°F.

RECOMMENDED OIL SUPPLY FOR STYLE S THRUST BEARINGS (ENGLISH)

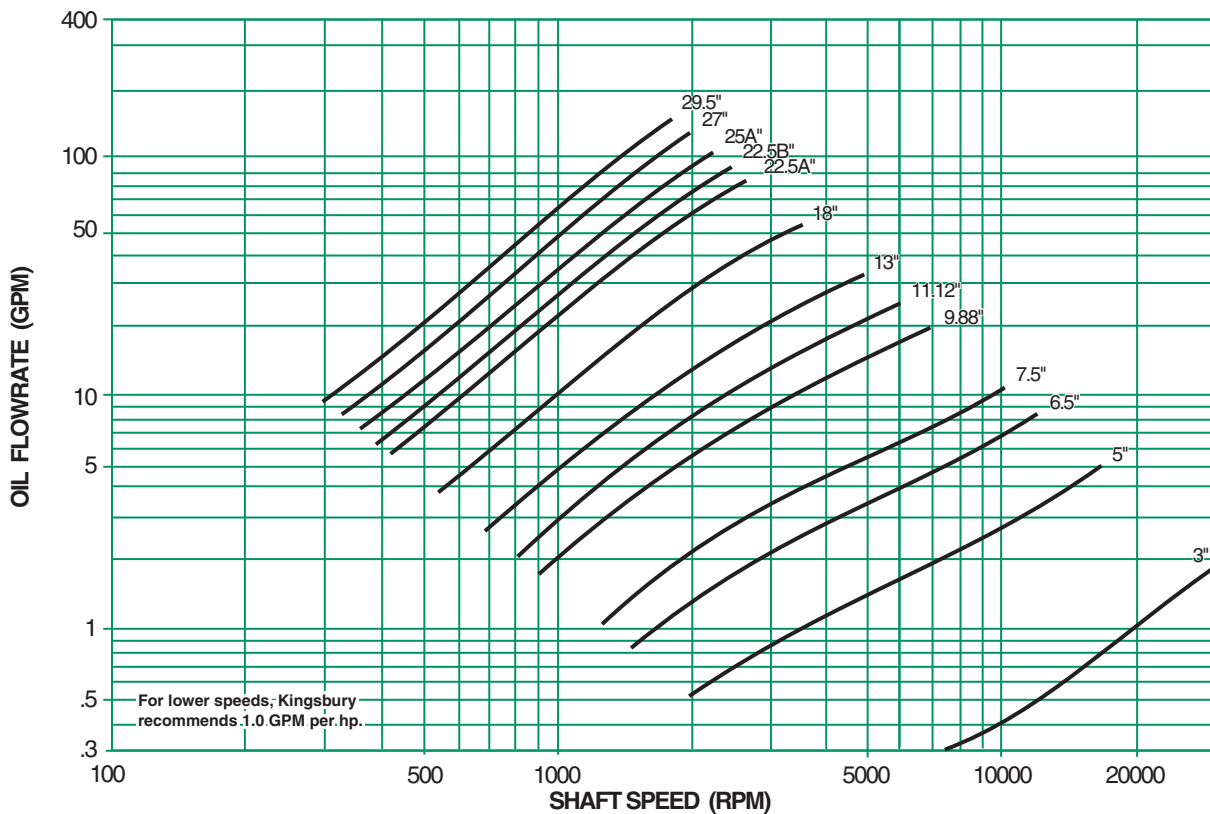
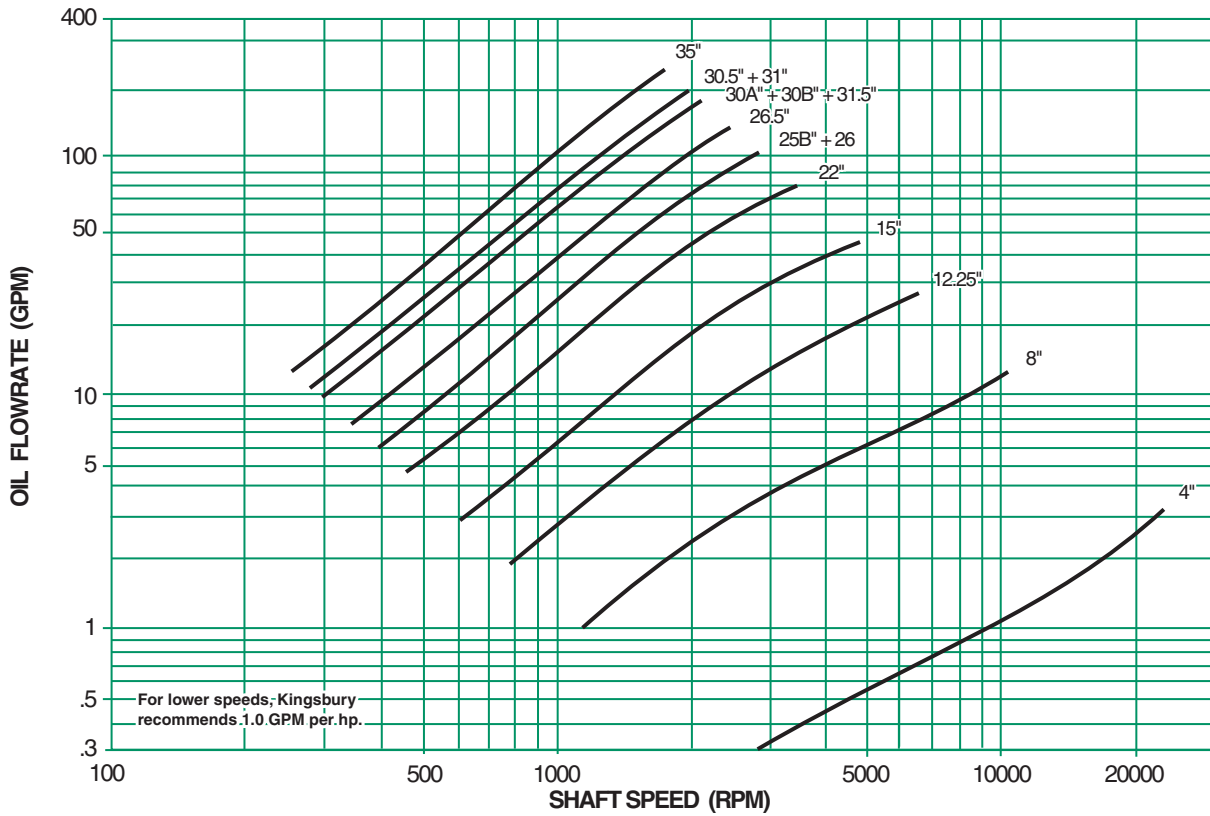

Based on 20% Slack Flow & ISO VG 32 supplied at 120°F.

This chart gives loaded side, single element flowrates for rated load. For double element bearings, supply an additional 20% to the inactive side. In machines where load may reverse and apply rated values to either side, provide equal flow to each side (a total of two times the chart value).

# POWER LOSS FOR DOUBLE ELEMENT STYLE S THRUST BEARINGS (ENGLISH)

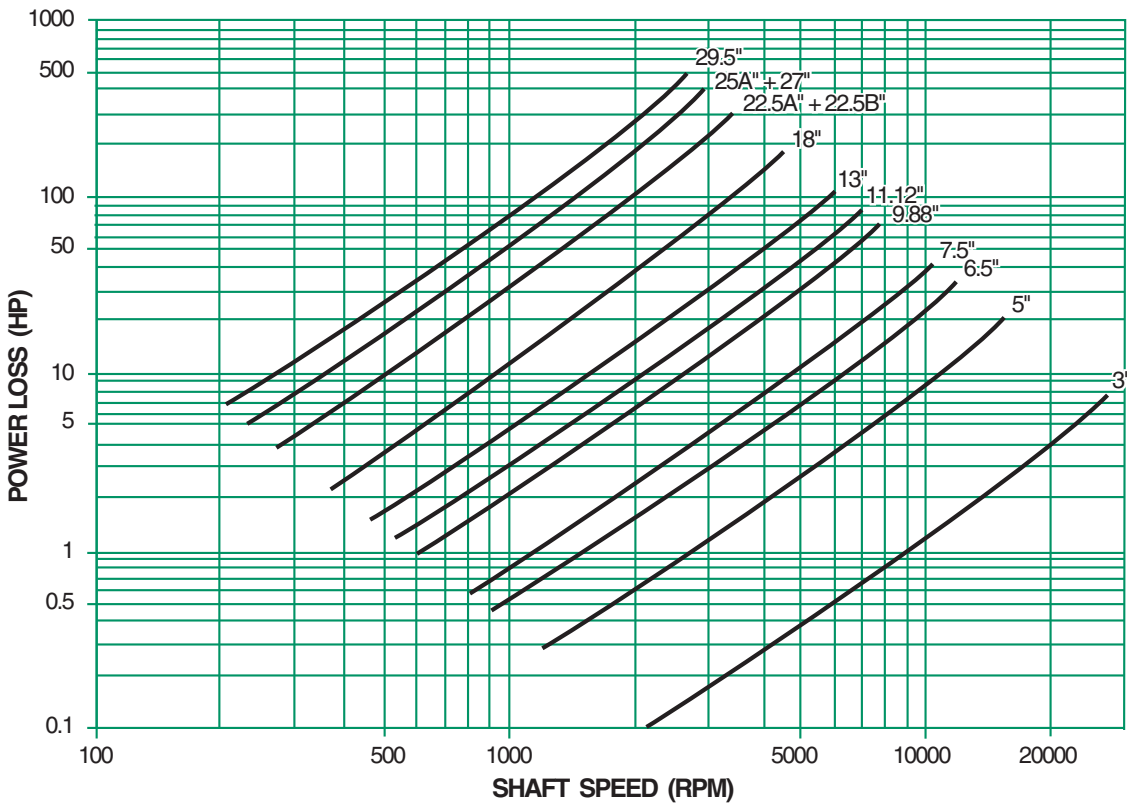
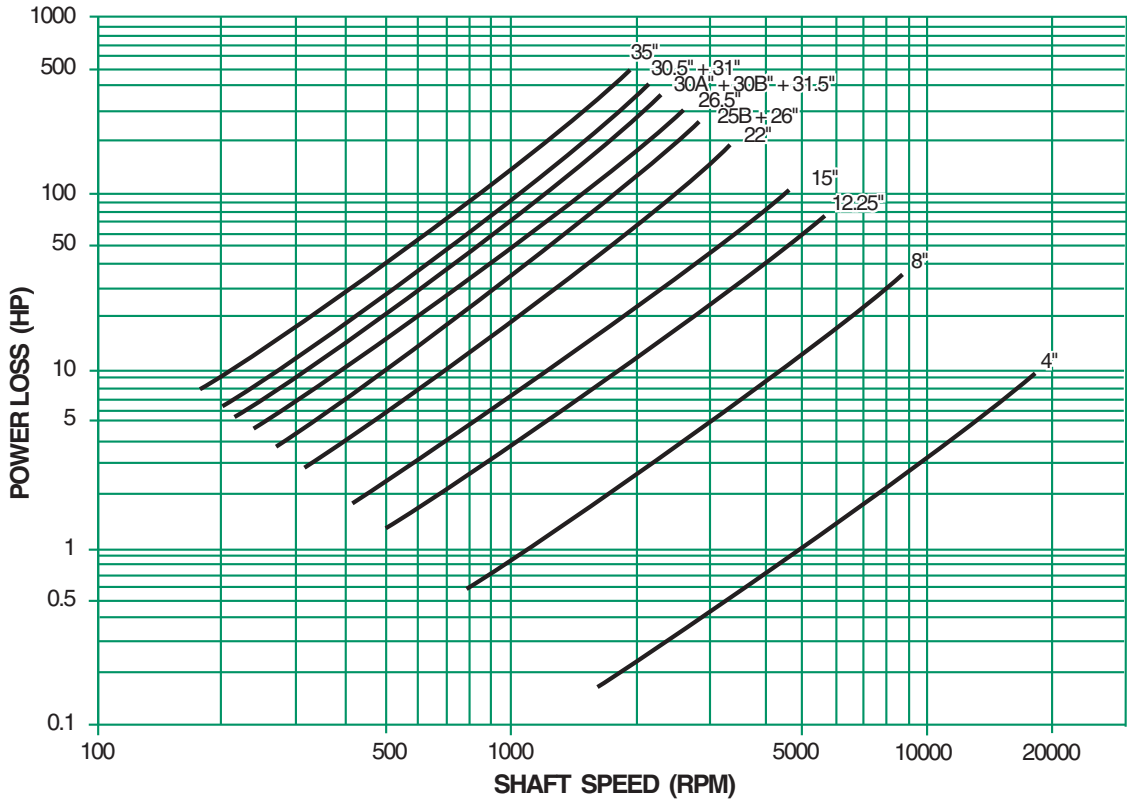

Based on 20% Slack Flow & ISO VG 32 supplied at 120°F.

This chart gives loaded side, single element flowrates for rated load. For double element bearings, supply an additional 20% to the inactive side. In machines where load may reverse and apply rated values to either side, provide equal flow to each side (a total of two times the chart value).

**POWER LOSS FOR SINGLE ELEMENT STYLE S THRUST BEARINGS (ENGLISH)**

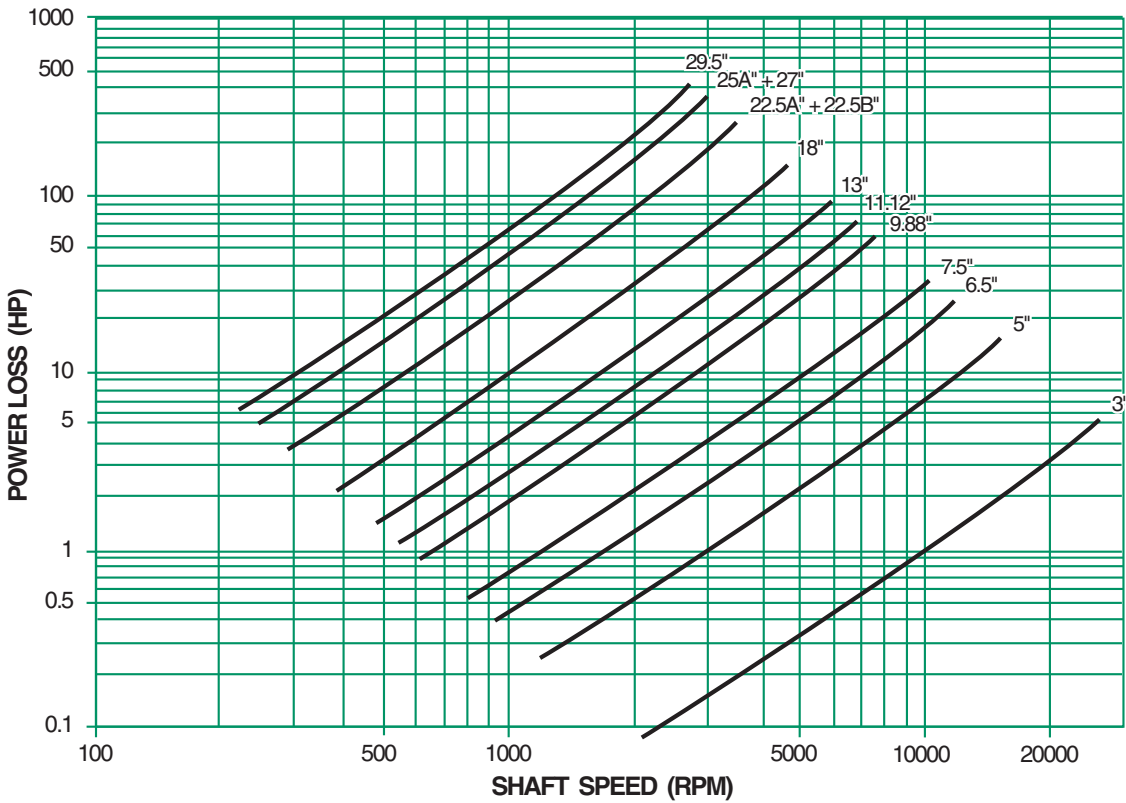
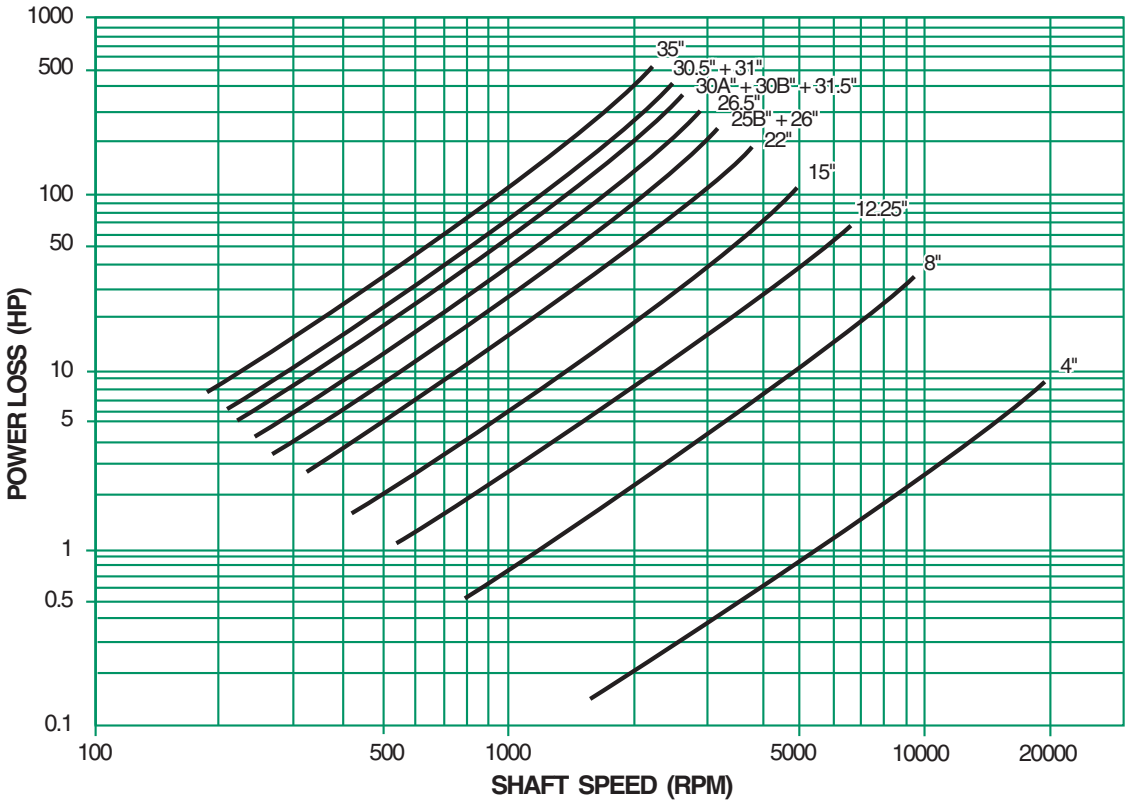

Based on 20% Slack Flow & ISO VG 32 supplied at 120°F.  
 This chart gives loaded side, single element flowrates for rated load. For double element bearings, supply an additional 20% to the inactive side. In machines where load may reverse and apply rated values to either side, provide equal flow to each side (a total of two times the chart value).

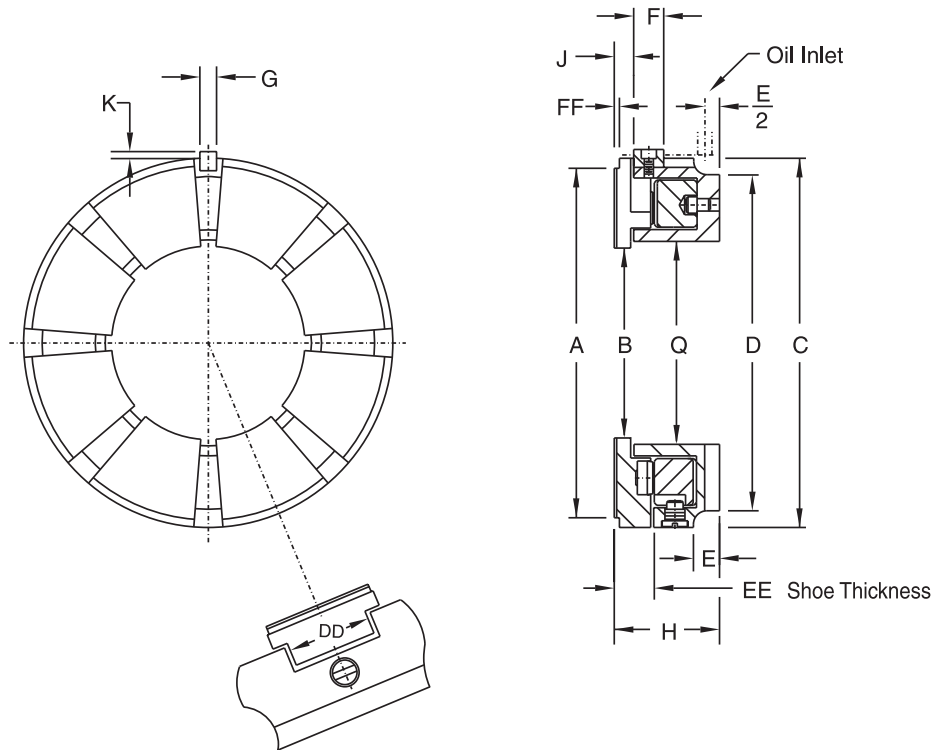

### Style S Bearings—Metric Conversion (mm), Sizes 3” through 26.5”

Bearing Size (inches)	3	4	5	6.5	7.5	8	9.88	11.12	12.25
Number of Shoes	4	4	8	8	8	8	12	8	8
Area (mm <sup>2</sup> )	2516	3870	5485	10000	13550	12900	22580	34840	34840
A – Babbitt O.D.	76.2	101.6	127.0	165.1	190.5	203.2	251.0	282.5	311.2
B – Babbitt I.D.	31.8	44.5	82.6	103.1	117.3	139.7	177.8	165.1	190.5
H – Bearing Height	31.8	41.1	39.6	39.6	50.8	49.3	47.8	69.9	58.7
C – Bearing O.D.	82.55	123.83	136.53	171.45	196.85	212.73	257.18	292.10	320.68
Q – Base ring I.D.	38.1	44.5	82.6	103.1	120.7	139.7	177.8	171.5	193.5
D – Oil annulus dia.	76.2	101.6	127.0	162.1	185.7	198.4	246.1	276.4	295.1
E – Oil annulus depth, min.	6.4	11.2	10.4	10.4	12.7	13.5	12.7	15.8	11.2
F – Bearing key, length	4.1	14.2	6.4	14.2	16.8	19.1	16.8	23.9	12.7
G – Bearing key, width	4.1	7.9	7.9	7.9	9.7	12.7	9.7	11.2	12.7
J – Collar to key	12.7	15.0	12.7	7.9	11.2	11.2	7.9	15.0	26.9
K – Key projection	4.1	4.1	3.1	4.1	4.8	4.8	4.8	4.8	4.8
M – Separate shaft dia.	28.5	36.6	76.2	98.6	111.3	133.4	168.2	155.5	180.8
N – Integral shaft dia.	25.4	31.8	69.9	92.0	104.7	127.0	158.8	149.4	177.8
P – Max dia. over fillet	28.5	39.6	76.2	98.6	112.8	134.9	173.0	160.3	187.5
R – Dia. through base ring	31.8	36.6	76.2	98.6	111.3	133.4	168.1	155.5	184.2
S – Shaft lgth @ shoe I.D.	11.2	–	–	–	–	–	–	15.8	28.4
X – Collar thickness	15.8	22.4	22.4	25.4	28.5	35.1	38.1	44.5	50.8
Y – Collar dia.	79.3	117.3	130.1	168.1	193.5	206.3	254.0	285.8	314.5
Z – Collar bore	22.23	28.58	71.12	88.90	104.78	114.30	152.40	139.70	165.10
T – Collar key depth	1.5	4.1	4.1	4.8	4.8	7.9	4.8	7.9	9.7
V – Collar key width	3.1	7.9	7.9	9.7	9.7	15.8	9.7	15.8	19.1
W – Collar chamfer	0.5	0.5	0.5	0.5	0.5	1.5	1.5	2.3	2.3
DD – Straddle mill	31.8	–	31.0	40.5	50.0	54.0	43.7	72.2	77.0
EE – Shoe thickness	11.12	14.30	12.65	14.27	19.84	17.45	19.84	28.58	28.58
FF – Shoe relief	3.1	7.1	3.1	4.8	3.1	–	3.3	4.8	7.9
Weight (kg) Bearing	0.7	2.5	2.3	3.63	5.90	7.26	11.34	20.4	21.8
Weight (kg) Collar	0.6	1.8	2.1	3.18	4.76	6.35	9.53	16.8	22.7
Weight (kg) Spare shoes	0.2	0.54	0.55	1.09	2.04	1.36	3.18	7.26	7.26

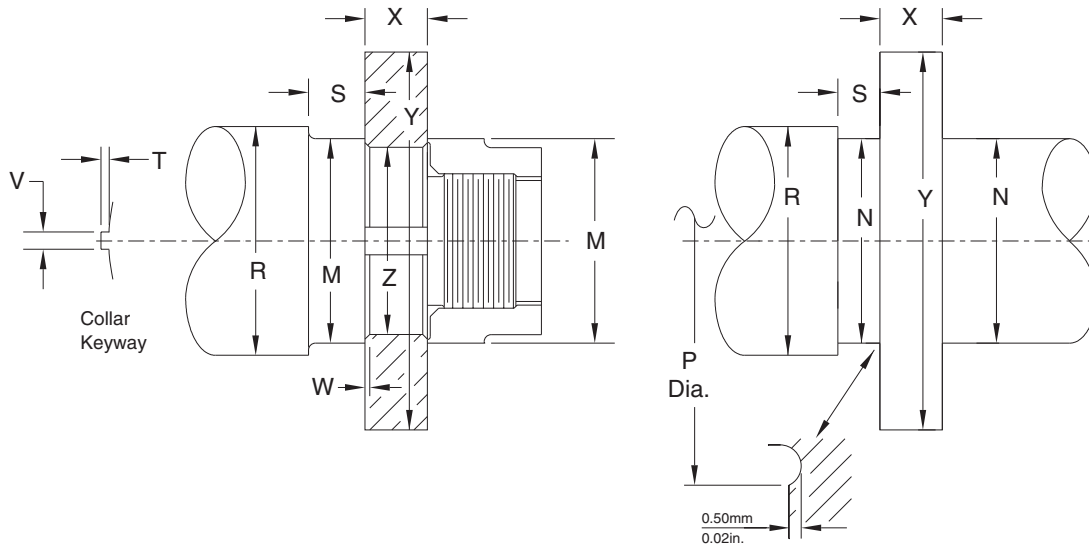

Bearing Size (inches)	13	15	18	22	22.5-A	22.5-B	25-A	25-B	26	26.5
Number of Shoes	8	10	8	10	8	8	8	8	8	8
Area (mm <sup>2</sup> )	46645	45160	58710	59355	98065	148385	170965	110965	103225	176130
A – Babbitt O.D.	330.2	381.0	457.2	558.8	571.5	571.5	635.0	635.0	660.4	673.1
B – Babbitt I.D.	196.9	266.7	311.2	412.8	355.6	330.2	381.0	431.8	457.2	431.8
H – Bearing Height	71.4	69.9	88.9	76.2	127.0	127.0	155.4	120.7	120.7	146.1
C – Bearing O.D.	342.90	393.70	476.25	571.50	587.38	587.38	673.10	660.40	679.45	685.80
Q – Base ring I.D.	206.2	269.7	323.9	425.5	355.6	355.6	396.7	412.8	457.2	431.8
D – Oil annulus dia.	327.2	378.0	454.2	549.1	561.8	561.8	628.7	639.8	642.9	639.8
E – Oil annulus depth, min.	19.1	17.5	22.4	19.1	31.8	31.8	30.2	44.5	42.9	60.5
F – Bearing key, length	23.9	23.9	30.2	30.2	41.1	41.1	63.5	35.1	35.1	53.8
G – Bearing key, width	11.2	11.2	14.2	14.2	19.1	19.1	28.4	25.4	25.4	28.4
J – Collar to key	16.8	28.4	19.1	16.8	28.4	28.4	63.5	25.4	25.4	28.4
K – Key projection	4.8	4.8	5.6	6.4	9.7	9.7	12.7	11.2	11.2	12.7
M – Separate shaft dia.	190.5	260.4	301.8	406.4	342.9	317.5	368.3	406.4	441.5	416.1
N – Integral shaft dia.	180.8	247.7	292.1	393.7	330.2	304.8	355.6	406.4	431.8	406.4
P – Max dia. over fillet	192.0	260.4	304.8	406.4	345.9	320.5	371.3	422.1	447.5	422.1
R – Dia. through base ring	196.9	260.4	314.5	406.4	342.9	345.9	384.0	457.2	454.2	450.9
S – Shaft lgth @ shoe I.D.	31.8	28.4	36.6	31.8	49.3	49.3	53.8	88.9	69.9	50.8
X – Collar thickness	57.2	63.5	76.2	50.8	82.6	82.6	108.0	108.0	114.3	101.6
Y – Collar dia.	335.0	385.8	463.6	565.2	577.9	577.9	641.4	641.4	666.8	679.5
Z – Collar bore	171.45	228.60	266.70	374.65	311.15	285.75	330.20	387.35	403.23	374.65
T – Collar key depth	9.7	12.7	12.7	9.7	15.7	15.7	19.1	19.1	19.1	19.1
V – Collar key width	19.1	25.4	25.4	19.1	31.8	31.8	38.1	38.1	38.1	38.1
W – Collar chamfer	2.3	2.3	3.0	7.9	4.1	4.1	4.1	4.1	4.1	4.1
DD – Straddle mill	81.0	81.0	104.0	81.0	126.2	126.2	177.0	127.0	133.4	165.1
EE – Shoe thickness	31.75	28.58	36.53	31.75	49.23	49.23	53.98	44.45	45.24	50.80
FF – Shoe relief	4.1	7.1	7.9	7.1	14.2	14.2	9.7	9.7	9.7	6.4
Weight (kg) Bearing	25.9	29.5	52.2	50.8	129.7	145.6	223.2	140.6	135.2	179.2
Weight (kg) Collar	29	38.1	61.2	55.3	120.2	127.9	199.6	172.4	197.3	199.6
Weight (kg) Spare shoes	11.3	9.5	15.9	13.6	35.4	50.8	71.2	39.9	34.9	68.9

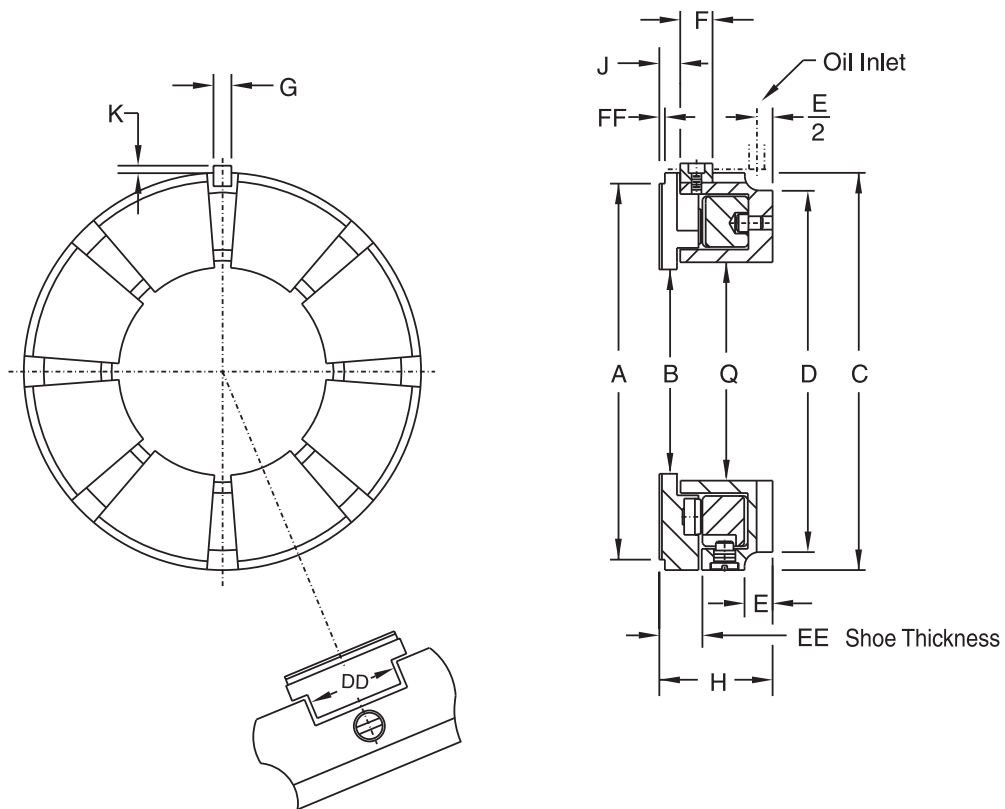

### Style S Bearings—Metric Conversion (mm), Sizes 27” through 72”

Bearing Size	27	29.5	30-A	30-B	30.5	31	31.5	35
Number of Shoes	8	8	18	8	8	8	20	8
Area (mm <sup>2</sup> )	214515	255485	143225	176775	258710	303225	133550	389030
A – Babbitt O.D.	685.8	749.3	762.0	762.0	774.7	787.4	800.1	889.0
B – Babbitt I.D.	393.7	431.8	609.6	482.6	469.9	419.1	660.4	469.9
H – Bearing Height	146.1	162.1	88.9	127.0	127.0	162.1	101.6	171.5
C – Bearing O.D.	704.85	768.35	762.00	781.05	781.05	806.45	812.80	908.05
Q – Base ring I.D.	393.7	431.8	616.0	495.3	495.3	431.8	660.4	490.5
D – Oil annulus dia.	663.4	730.3	732.8	730.3	730.3	730.3	787.4	835.2
E – Oil annulus depth, min.	49.3	62.0	26.9	57.2	41.1	62.0	38.1	50.8
F – Bearing key, length	57.2	47.8	30.2	41.1	41.1	47.8	30.2	57.2
G – Bearing key, width	31.8	31.8	14.2	25.4	25.4	31.8	14.2	31.8
J – Collar to key	31.8	35.1	19.1	28.4	28.4	35.1	22.4	41.1
K – Key projection	12.7	12.7	7.9	11.2	11.2	12.7	7.9	12.7
M – Separate shaft dia.	374.7	419.1	584.2	457.2	457.2	406.4	635.0	457.2
N – Integral shaft dia.	358.6	406.4	568.5	441.5	428.8	378.0	365.0	431.8
P – Max dia. over fillet	381.0	422.1	593.9	466.9	454.2	403.4	650.7	457.2
R – Dia. through base ring	419.1	482.6	600.0	514.4	514.4	476.3	641.4	539.8
S – Shaft lgth @ shoe I.D.	82.6	98.6	35.1	76.2	76.2	98.6	38.1	104.6
X – Collar thickness	114.3	127.0	63.5	130.0	133.4	133.4	133.4	152.4
Y – Collar dia.	692.2	755.7	765.0	768.4	777.7	793.8	806.5	895.4
Z – Collar bore	342.90	374.65	533.40	419.10	412.75	361.95	584.20	400.05
T – Collar key depth	19.1	22.4	15.7	22.4	22.4	22.4	22.4	25.4
V – Collar key width	38.1	44.5	31.8	44.5	44.5	44.5	44.5	50.8
W – Collar chamfer	4.1	4.8	3.0	4.8	4.8	4.8	4.8	6.4
DD – Straddle mill	167.49	184.15	99.21	146.05	196.85	196.85	95.25	209.55
EE – Shoe thickness	53.98	66.68	34.93	50.80	50.80	67.46	38.10	76.20
FF – Shoe relief	9.7	12.7	–	12.7	11.2	12.7	4.8	12.7
Weight (kg) Bearing	250.4	310.7	112.5	195.0	216.8	326.6	108.9	453.6
Weight (kg) Collar	254.0	335.7	117.9	331.1	353.8	408.2	258.5	589.7
Weight (kg) Spare shoes	88.5	117.9	34.9	61.7	83.5	152.4	36.3	201.8



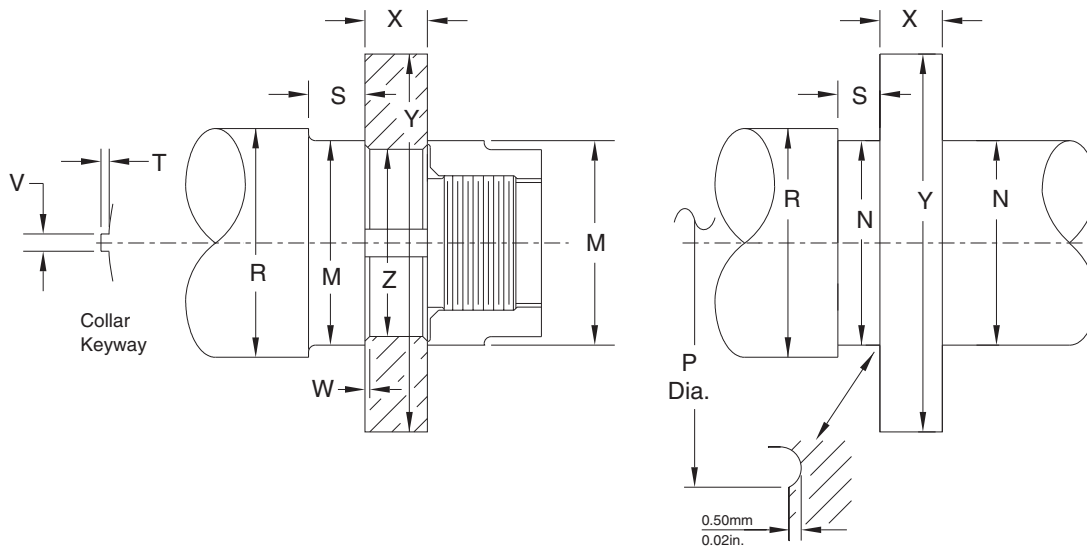

Bearing Size	39	41	43	45	46	50	54	61	65	72
Number of Shoes	8	8	8	8	8	8	8	8	8	8
Area (mm <sup>2</sup> )	512,257	603,547	523,547	654,837	604,383	757,740	862,579	1,222,900	1,510,965	1,600,000
A – Babbitt O.D.	990.6	1041.4	1092.2	1143.0	1168.4	1270.0	1371.6	1549.4	1651.0	1828.8
B – Babbitt I.D.	457.2	457.2	635.0	596.9	673.1	685.8	762.0	762.0	711.2	965.2
H – Bearing Height	184.1	184.1	215.9	228.6	228.6	254.0	270.0	282.7	319.0	210.2
C – Bearing O.D.	1047.75	1079.50	1117.60	1168.40	1193.80	1289.05	1390.65	1568.45	1670.05	1854.20
Q – Base ring I.D.	514.3	514.3	660.4	701.8	679.4	900.0	800.1	857.2	787.4	1016.0
D – Oil annulus dia.	933.4	933.4	1060.4	1117.6	1117.6	1225.5	1314.4	1441.4	1568.4	1753.0
E – Oil annulus depth, min.	42.9	42.9	50.8	98.4	95.2	82.5	107.9	101.6	112.7	127.0
F – Bearing key, length	82.5	82.5	69.8	44.4	44.4	76.2	50.8	50.8	127.0	127.0
G – Bearing key, width	44.4	44.4	44.4	44.4	44.4	50.8	50.8	50.8	69.8	69.8
J – Collar to key	47.7	47.7	52.3	76.4	76.4	82.5	82.5	95.2	79.5	98.4
K – Key projection	16.0	16.0	16.0	31.7	31.7	19.0	25.4	25.4	38.1	35.0
M – Separate shaft dia.	400.0	400.0	603.2	565.1	641.3	647.7	723.9	723.9	666.7	920.7
N – Integral shaft dia.	377.8	377.8	577.8	539.7	609.6	622.3	698.5	698.5	637.5	895.3
P – Max dia. over fillet	435.1	435.1	612.9	596.9	647.7	660.4	736.6	736.6	685.8	939.8
R – Dia. through base ring	584.2	600.7	685.8	647.7	730.2	800.1	857.2	939.8	882.6	1117.6
S – Shaft lgth @ shoe I.D.	114.3	114.3	127.0	139.7	127.0	152.4	168.4	177.8	190.5	222.2
X – Collar thickness	177.8	177.8	184.1	193.8	193.8	228.6	241.3	266.7	279.4	292.1
Y – Collar dia.	1003.3	1066.8	1104.9	1155.7	1181.1	1282.7	1384.4	1562.1	1663.7	1847.8
Z – Collar bore	355.60	355.60	558.80	527.05	590.55	596.90	673.10	673.10	615.95	869.95
T – Collar key depth	28.7	28.7	28.7	28.7	28.7	31.7	31.7	35.0	35.0	38.1
V – Collar key width	57.1	57.1	57.1	57.1	57.1	63.5	63.5	69.8	69.8	69.8
W – Collar chamfer	9.3	9.6	9.6	9.6	9.6	12.7	12.7	16.0	16.0	19.0
DD – Straddle mill	233.4	233.4	281.8	281.8	304.4	328.6	379.4	423.9	449.3	428.6
EE – Shoe thickness	83.62	84.12	92.07	92.07	95.25	107.95	114.30	127.00	139.70	155.57
FF – Shoe relief	28.2	2.8	6.1	12.4	6.1	6.1	9.4	9.1	12.4	15.5
Weight (kg) Bearing	748	816	941	953	1043	1315	1678	2359	3402	4309
Weight (kg) Collar	928	982	1252	1261	1247	1814	2177	3266	4128	4763
Weight (kg) Spare shoes	302	327	318	376	372	513	626	953	1361	1542

## RATED LOAD FOR STYLE S THRUST BEARINGS (METRIC)

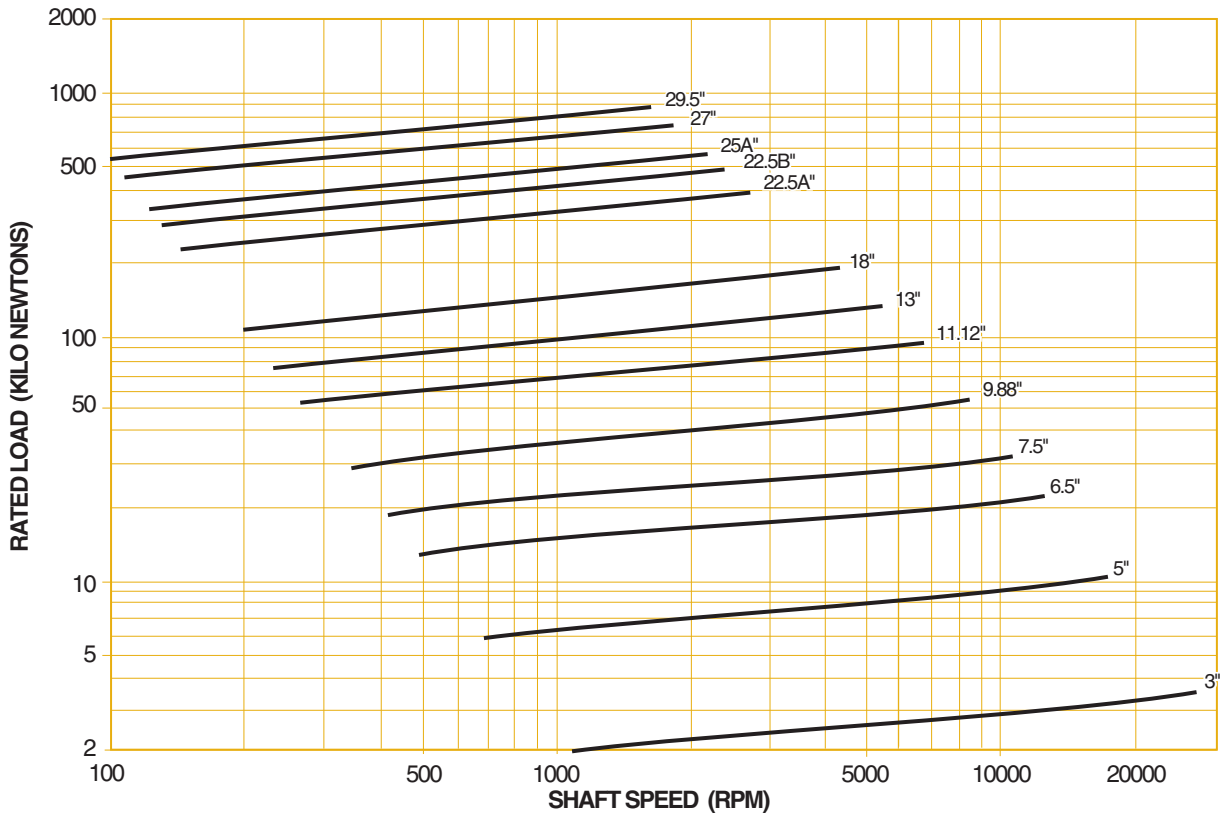
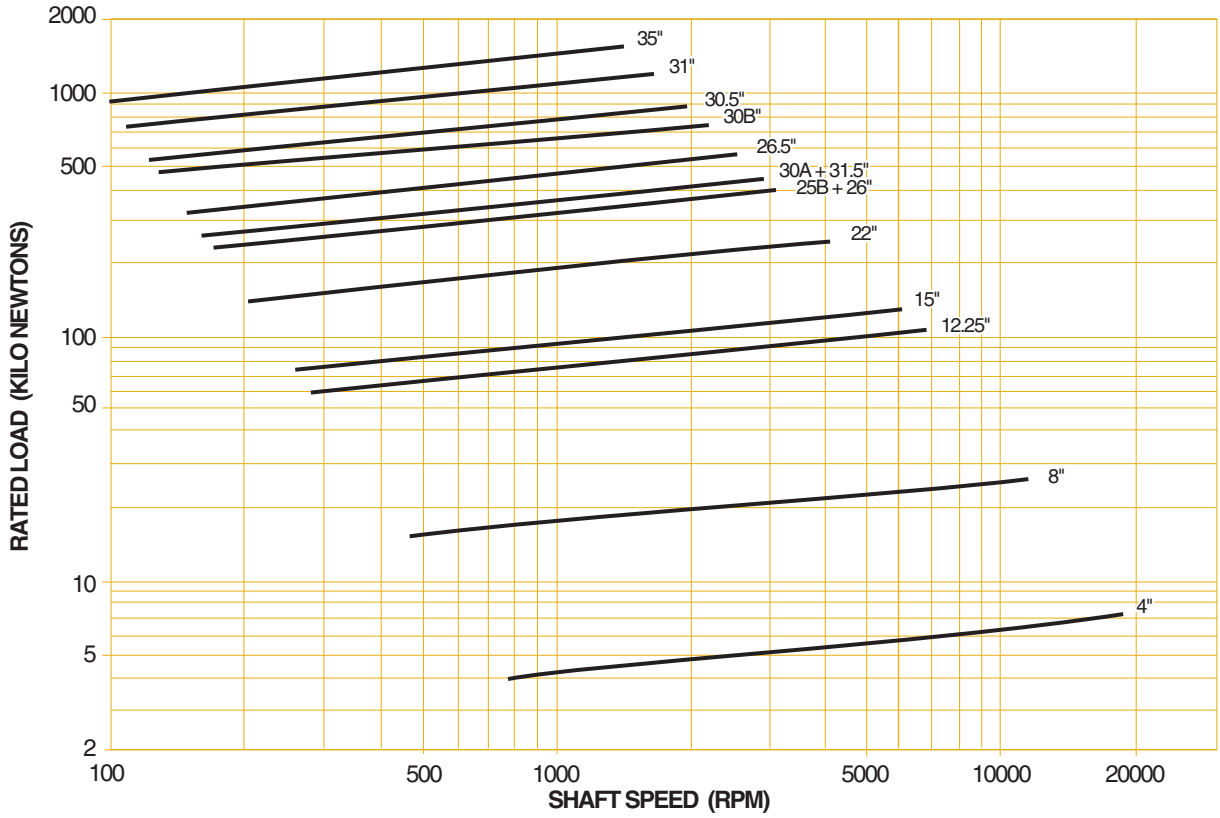

Based on ISO VG 32 supplied at 50°C.

## RECOMMENDED OIL SUPPLY FOR STYLE S THRUST BEARINGS (METRIC)

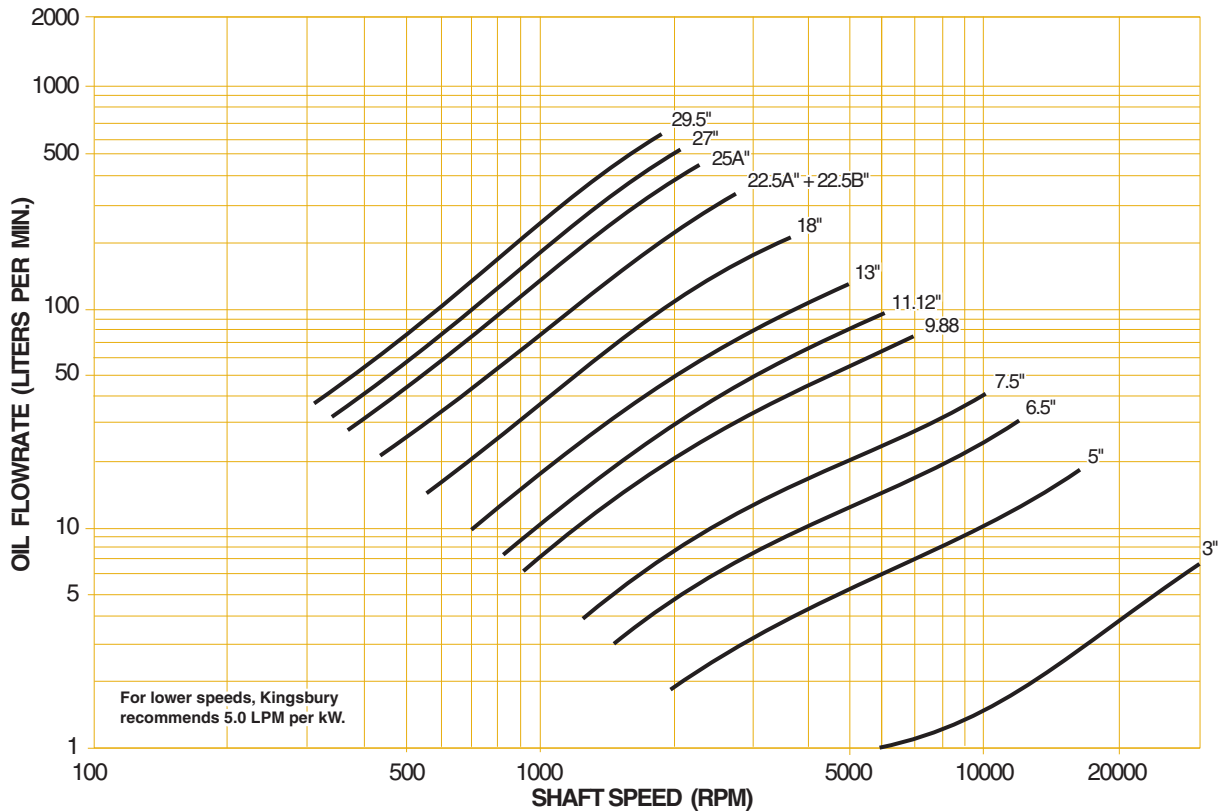
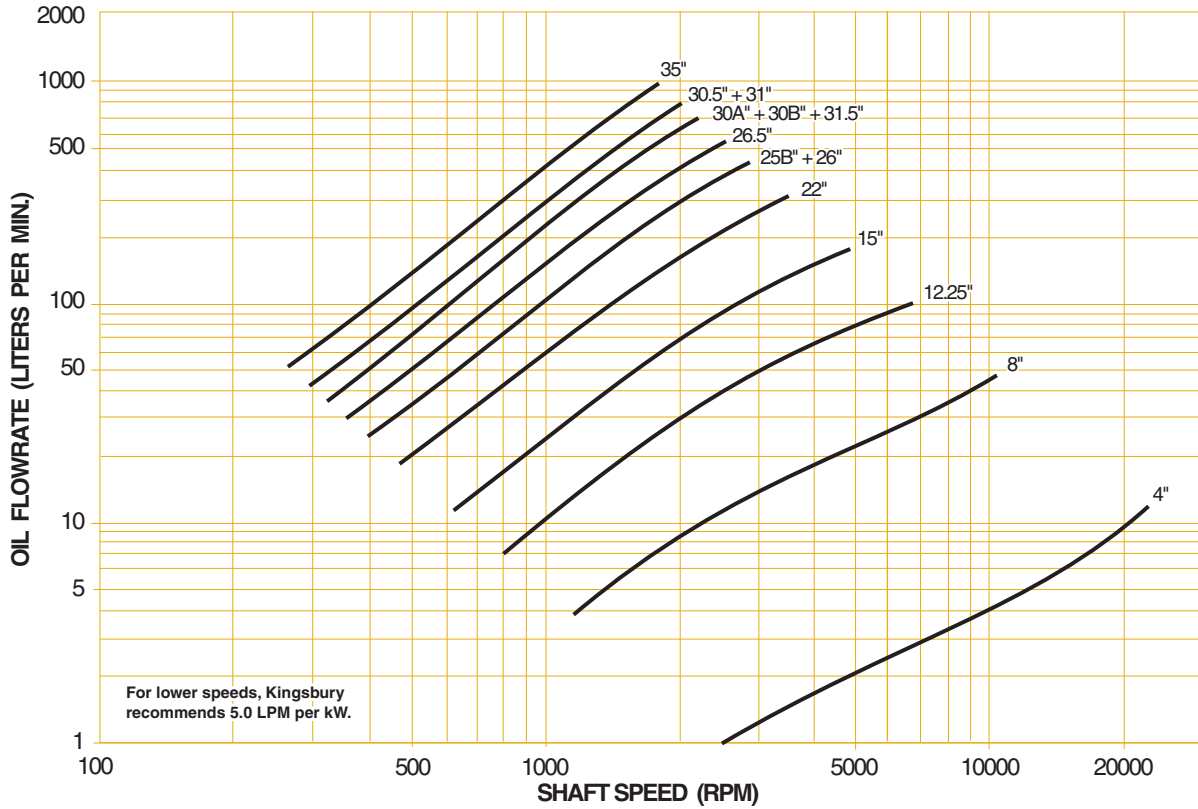

Based on 20% Slack Flow & ISO VG 32 supplied at 50°C.

This chart gives loaded side, single element flowrates for rated load. For double element bearings, supply an additional 20% to the inactive side. In machines where load may reverse and apply rated values to either side, provide equal flow to each side (a total of two times the chart value).

## POWER LOSS FOR DOUBLE ELEMENT STYLE S THRUST BEARINGS (METRIC)

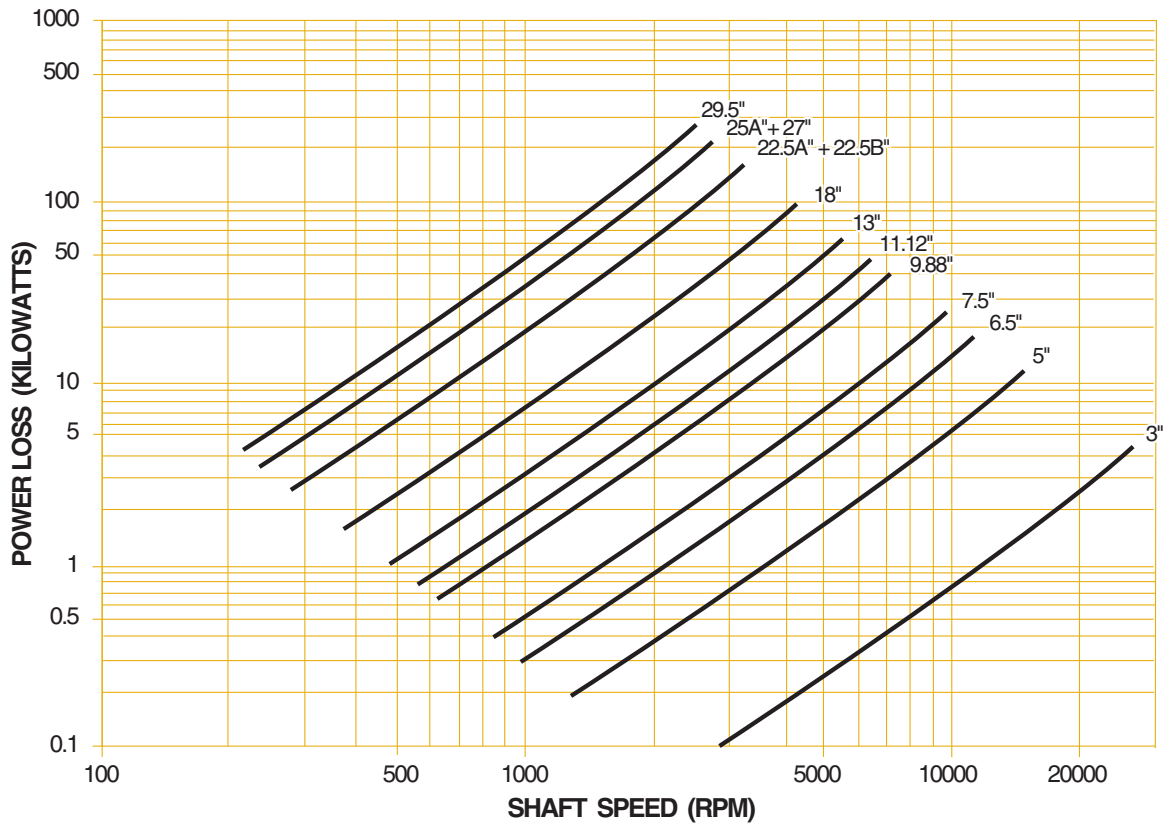
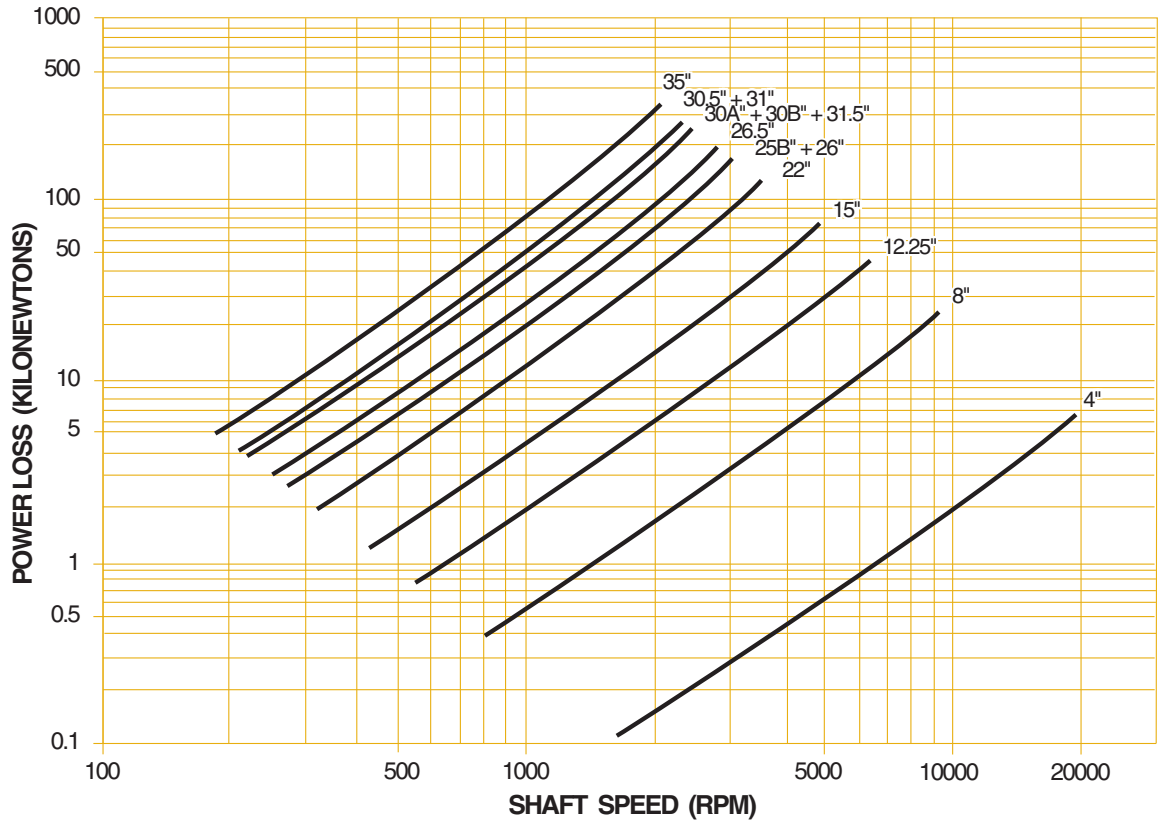

Based on 20% Slack Flow & ISO VG 32 supplied at 50°C.

Power loss is based on rated load, recommended oil flow, and Kingsbury's recommended discharge configuration.

If any of these is changed the power loss will also change.

POWER LOSS FOR SINGLE ELEMENT STYLE S THRUST BEARINGS (METRIC)

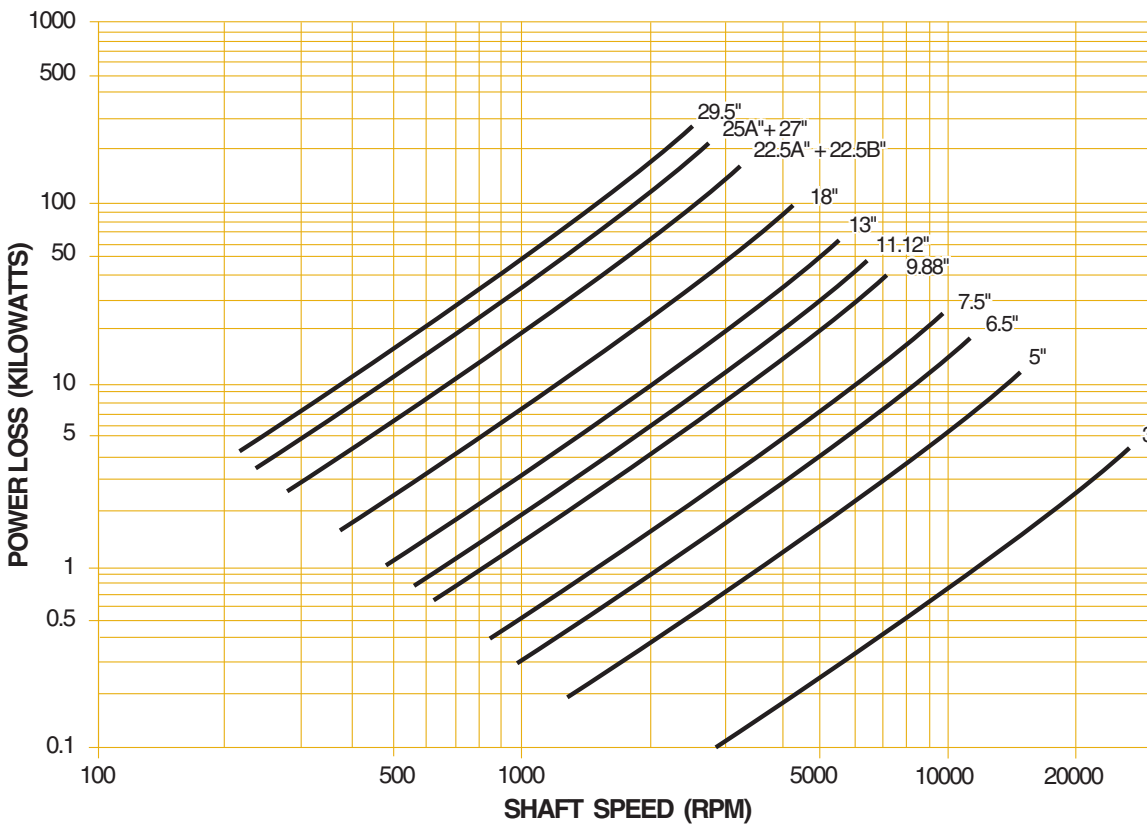
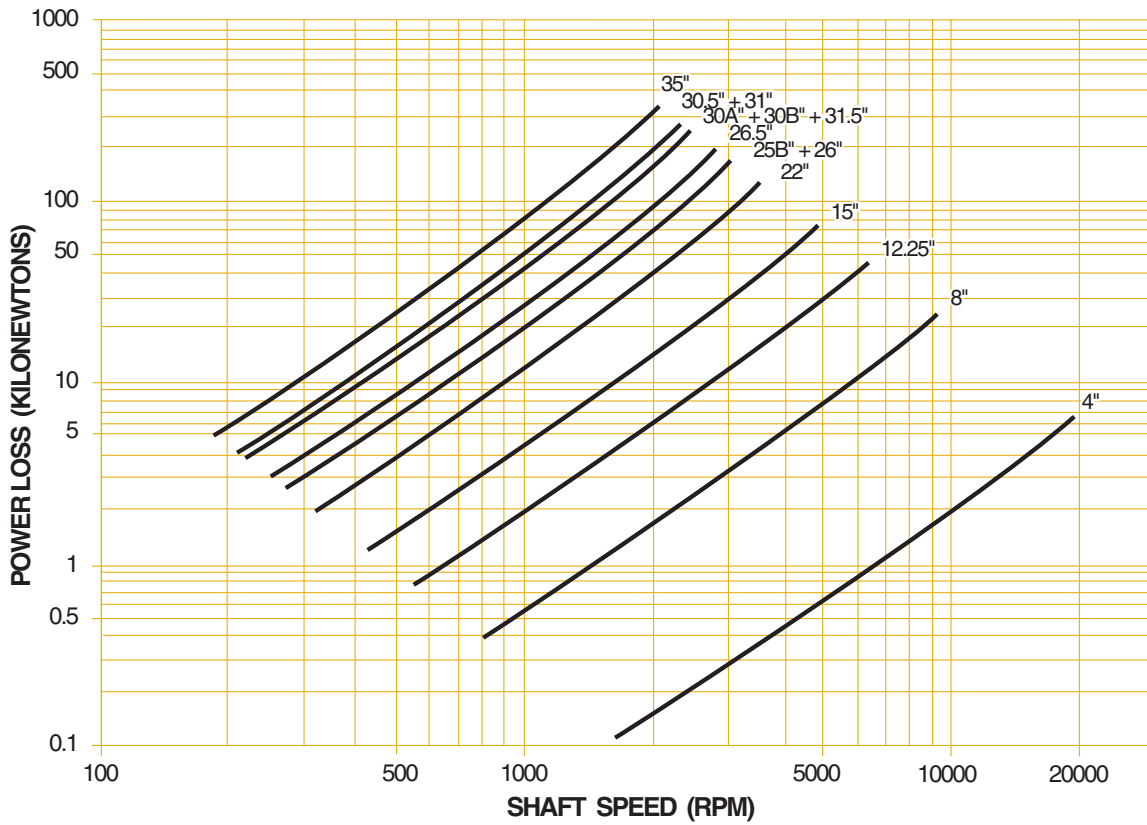

Based on 20% Slack Flow & ISO VG 32 supplied at 50°C.  
Power loss is based on rated load, recommended oil flow, and Kingsbury's recommended discharge configuration.  
If any of these is changed the power loss will also change.

## HOW TO ESTIMATE BABBITT TEMPERATURE

Once you have selected the correct thrust bearing style and size, you may want to estimate the babbitt temperature of the operating bearing. This is a good design practice when:

- Bearing loading exceeds 400PSI (2.8 Mpa),
- Collar surface speed exceeds 15,000 feet per minute (76.2 m/s),
- Inlet oil temperature exceeds 120°F (50°C) or,
- Specifications limit maximum allowable temperature.

To estimate the babbitt temperature at the recommended 75/75 position, use the graph on this page for steel shoes. If the temperature exceeds 265°F (130°C), you may be able to reduce it to a more acceptable level by substituting chrome-copper-backed shoe or offset-pivot steel shoes. Consult the graphs on page 39 to determine if this is the case. For those applications where the babbitt temperature still exceeds 265°F (130°C), contact our Engineering Department for additional suggestions.

### Using the Babbitt Temperature Curves

Our experimental work with a variety of shoe designs and materials indicates that the graphs on these pages can be applied with reasonable accuracy to the J, B, E, and S styles of bearings.

The curves are based upon tests performed in our Research and Development Center using 10.5" diameter, six and eight shoe bearings, operated with light turbine oil [150 SSU @ 100°F; 32cSt @ 40°C] supplied at 115°F (46°C).

All measurements were taken at the 75/75 position, as indicated on the drawing below.

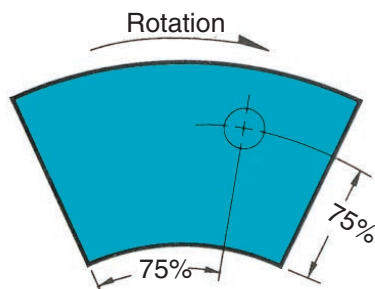

## Babbitt Temperatures for Steel Center-Pivot Shoes

Babbitt Temperatures @ 75/75 Positions

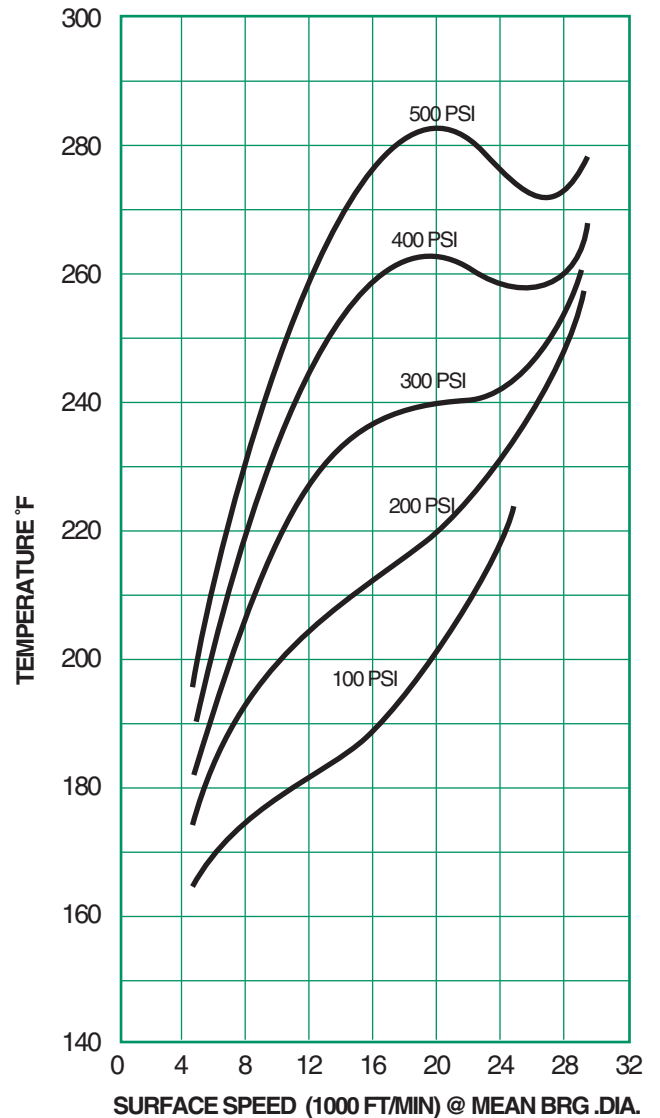

### Babbitt Temperatures for Chrome-Copper Shoes

Temperatures @ 75/75 Position

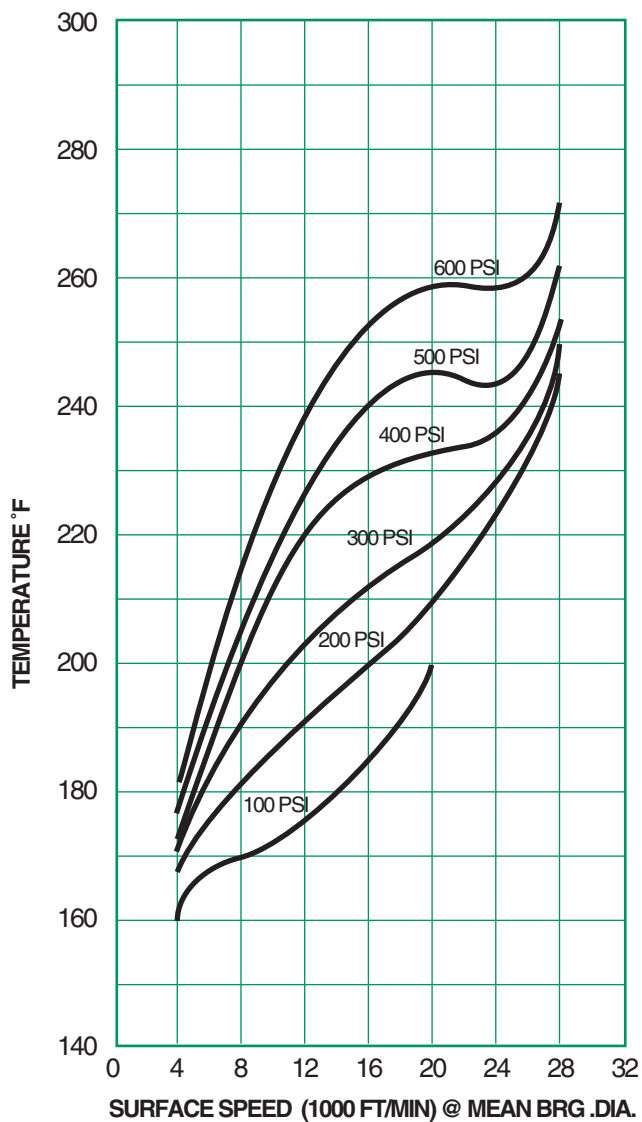

### Babbitt Temperatures for Steel Offset-Pivot Shoes

Temperatures @ 75/75 Position

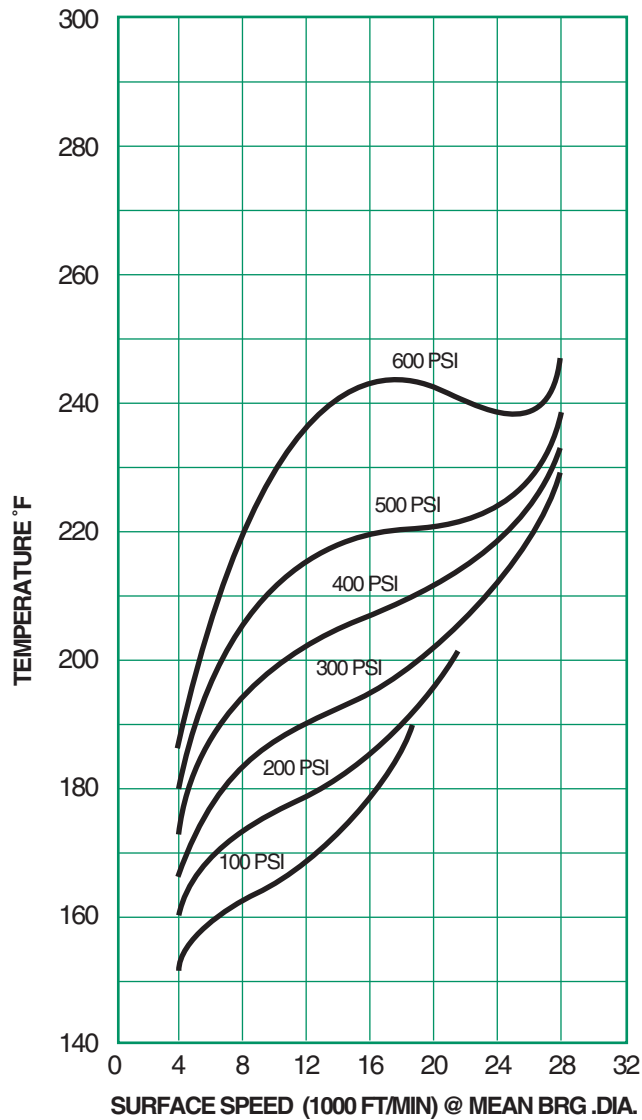

## SHOE TEMPERATURE PATTERN VARIATIONS

A temperature sensor mounted at the 75/75 position can provide the critical shoe temperature for that one, fixed location, but cannot indicate the temperature pattern over the entire shoe surface. In order to demonstrate the localized nature of the critical temperature region, we rely on isotherms (lines of constant temperature) based upon an array of 9 thermocouples evenly distributed across the shoe surface, plus a tenth thermocouple at the 75/75 location. The sensors are embedded in the babbitt material, approximately 0.03" (0.76 mm) below the shoe working surface. Values from all ten thermocouples are curve-fit in the circumferential and radial directions to obtain intermediate temperature values at other locations on the shoe. These combined measured and intermediate temperatures are plotted as isotherms in the accompanying illustrations.

The isotherms shown here demonstrate the changing temperature patterns which develop under various operating conditions.

For example:

- Thermal conduction, supply groove mixing, and hot oil carryover conspire to raise leading edge temperatures as high as 140°F (60°C) for standard oil flow rates, despite the cool 115°F (46°C) oil supply temperature.
- Raising the oil flow rate reduces leading edge temperatures by only a few degrees.

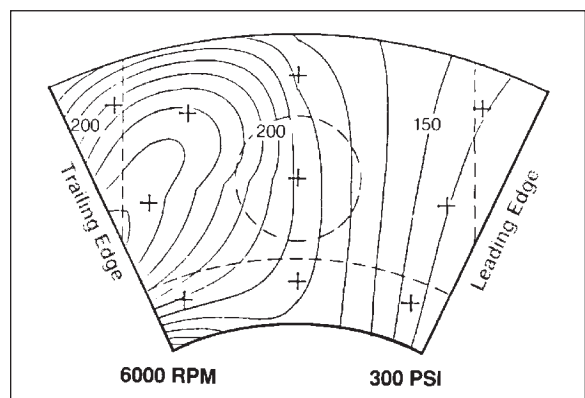
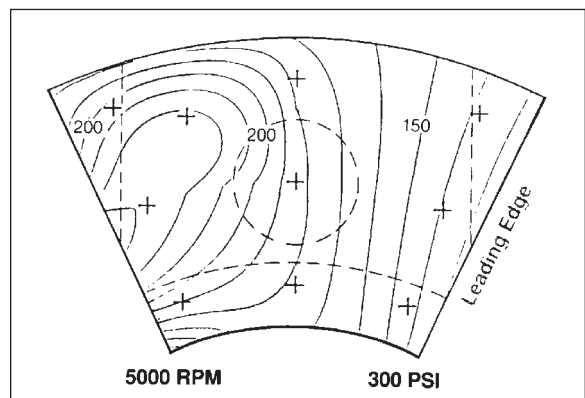
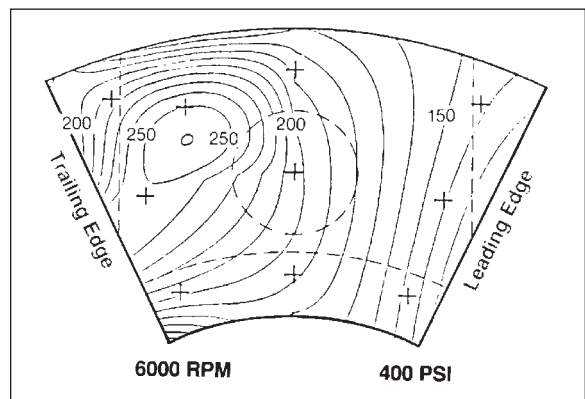
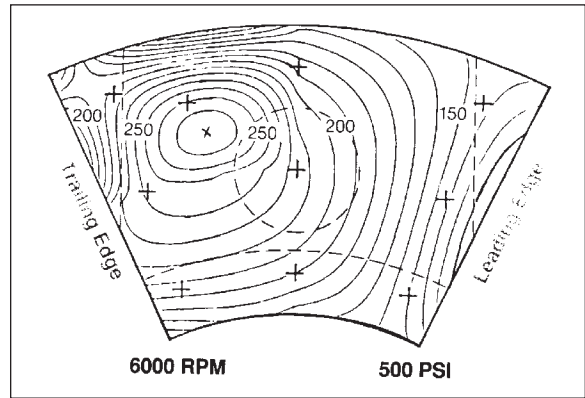



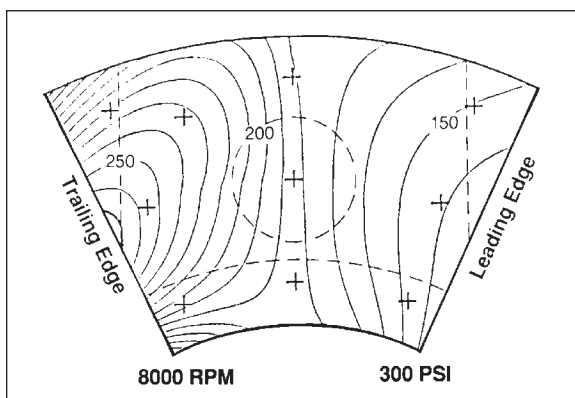
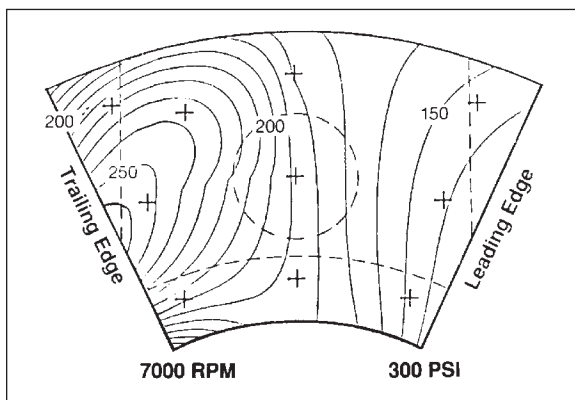
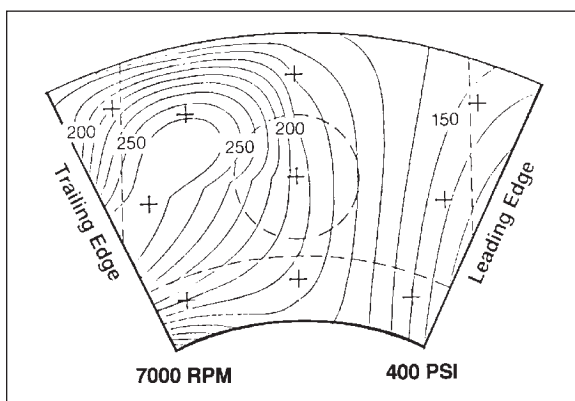
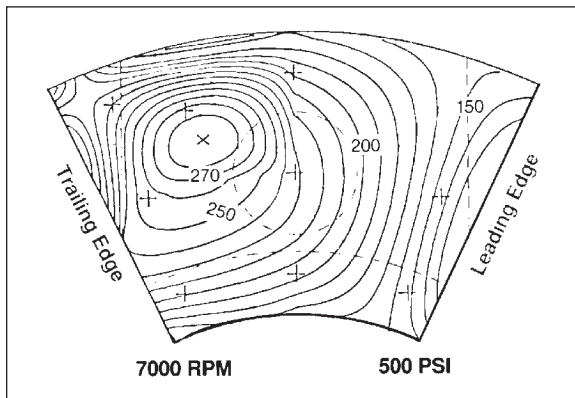

## Temperature Parameters

Measured temperatures will vary according to:

- Shaft speed
- Load
- Oil flow rate
- Oil viscosity
- Shoe design
- Type of shoe metal (thermal conductivity)
- Depth of installed sensor

Moving across the shoe from the leading edge to center pivot, the isotherms are widely and uniformly spaced in a near-radial pattern. What is the cause? Relatively thick oil film and minimal deflection of the shoe.

Beyond the shoe's center, the thermal gradient becomes much steeper and more indicative of the actual oil film thickness.

Sometimes, thermal crowning and load distortions produce a distinct hot spot such as that shown at 6000 RPM, 500 PSI (3.45 MPa), with a temperature above 270°F (132°C).

**Important:** In a region of high oil film pressure, such a critical temperature is much more dangerous than a hot spot developing at a trailing edge for 6000 RPM, 300 PSI (2.07 Mpa), where the parabolic pressure distribution falls to zero.

By varying some of the factors which influence shoe temperature, we can evaluate overall bearing temperature performance based upon that change. For example, we have been able to measure the effects of reducing shoe thickness and using a smaller shoe support in our bearings. For results of these comprehensive tests, contact our Engineering Department.

## OIL DISCHARGE CONFIGURATIONS

We have conducted experimental tests on a variety of oil discharge configurations. The results? We have found that overall bearing power loss and performance are affected by:

- Radial or tangential discharges,
- The clearance between the rotating thrust collar and the stationary housing, and
- The diameter of the discharge port.

For high speed applications, our recommended discharge dimensions have been incorporated in a separate bearing accessory called an oil control ring. The oil control ring fits into the housing as a stationary shroud that provides proper clearance around the rotating thrust collar, and includes a properly sized tangential

discharge opening. You can find bearing housing dimensions for oil control ring installation on the following pages.

In the event that an oil control ring cannot be used, you may wish to machine your housing for an optimized discharge configuration. You will find our recommended values for these critical discharge dimensions on pages 44-45.

### Designer's guide to lubrication

- We recommend a tangential discharge opening for all applications, especially those with a surface speed above 4,500 feet per minute (22.86 m/s) at mean diameter. This discharge configuration reduces power loss by minimizing oil churning and excessive back pressure.
  - Radial discharge openings can be used where speeds
- are lower and ample passages follow the discharge opening. In some cases, radial-opening performance can be improved by placing a recess around the opening to decelerate the discharge oil. Such a recess allows the oil to change direction with minimal disturbance.
  - The discharge opening should be located in the top half of the bearing housing.
  - Oil flow should be started prior to shaft rotation wherever practical. If this isn't possible, retain some oil for initial lubrication in the bearing cavity.
  - Oil flow volume is best controlled at the inlet to the bearing, not at the discharge outlet.
  - Oil passages in the thrust bearing base ring are designed for flow velocities of six to eight feet per second (1.8-2.4 m/s).



The oil inlet orifice may be sized by the thin plate orifice formula:

$$Q = 19.4d^2 \sqrt{\frac{P}{S}}$$

Where Q = required oil flow, gallons per minute  
d = inlet orifice diameter, inches  
P = oil pressure, pounds per square inch  
S = specific gravity

If the oil inlet hole(s) is long, flow losses must be considered.

$$\frac{Q}{264.2} = \text{Oil flow in cubic meters per minute}$$

**Oil Control Ring**

## Oil Control Rings

The oil control ring controls the discharge of oil from the bearing.

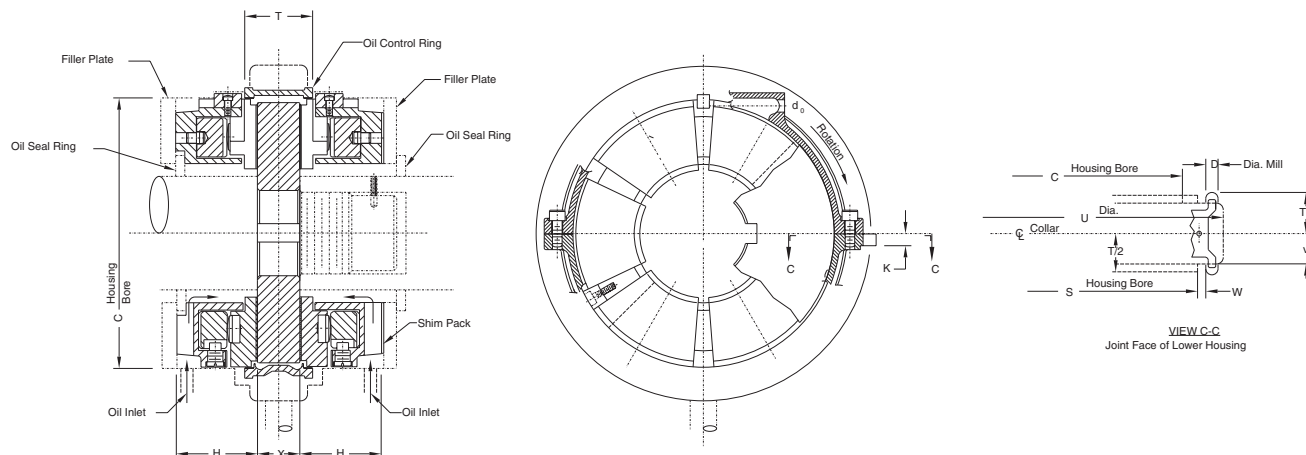

### Style J, B, and E Bearings—English Units (inches)

Bearing Size	4.0	5.0	6.0	7.0	8.0	9.0	10.5	12.0	13.5	15.0	17.0
Housing Bore "C"	4.375	5.375	6.375	7.375	8.375	9.375	11.000	12.500	14.000	15.500	17.625
Thrust Cavity "H"	1.44	1.75	2.06	2.38	2.69	3.00	3.38	3.75	4.25	4.62	5.25
Housing Bore "S"	4.875	5.875	6.875	7.875	9.000	10.000	11.625	13.250	14.875	16.500	18.750
T (Housing)	1.375	1.375	1.625	2.000	2.250	2.500	2.875	3.250	3.625	4.000	4.500
U	6.75	7.75	8.75	9.75	10.75	12.00	13.75	15.50	17.50	19.50	22.00
V	0.50	0.50	0.69	0.88	1.00	1.06	1.25	1.44	1.69	1.75	2.00
Collar Thickness "X"	0.88	0.88	1.00	1.25	1.38	1.50	1.75	2.00	2.25	2.50	2.88
Oil Outlet Diameter $d_o$	0.31	0.31	0.38	0.44	0.56	0.56	0.30	0.50	0.56	0.56	0.66
TT	0.88	0.88	1.06	1.25	1.38	1.50	1.69	1.88	2.25	2.38	2.62
W	0.31	0.31	0.25	0.25	0.25	0.28	0.34	0.34	0.38	0.38	0.41
Diameter Mill "D"	0.50	0.50	0.56	0.50	0.50	0.50	0.50	0.50	0.62	0.75	0.62
Depth of Milled Slots "K"	0.25	0.25	0.31	0.38	0.38	0.38	0.50	0.50	0.50	0.56	0.62

### Style J, B, and E Bearings—Metric Conversions (mm)

Bearing Size	101.6	127.0	152.4	177.8	203.2	228.6	266.7	304.8	342.9	381.0	431.8
Housing Bore "C"	111.12	136.52	161.92	187.32	212.72	238.12	279.40	317.50	355.60	393.60	447.68
Thrust Cavity "H"	36.6	44.5	52.3	60.5	68.3	76.2	85.9	95.3	108.0	117.4	133.4
Housing Bore "S"	123.83	149.23	174.63	200.03	228.60	254.00	295.28	336.55	377.83	419.10	476.25
T (Housing)	34.93	34.93	41.28	50.80	57.15	63.50	73.03	82.55	92.08	101.60	114.30
U	171.5	196.9	222.3	247.7	273.1	304.8	349.3	393.7	444.5	495.3	558.8
V	12.7	12.7	17.5	22.4	25.4	26.9	31.8	36.6	42.9	44.5	50.8
Collar Thickness "X"	22.4	22.4	25.4	31.8	35.1	38.1	44.5	50.8	57.2	63.5	73.2
Oil Outlet Diameter $d_o$	7.9	7.9	9.7	11.2	14.2	14.2	7.6	12.7	14.2	14.2	16.8
TT	22.4	22.4	26.9	31.8	35.1	38.1	42.9	47.8	57.2	60.5	66.5
W	7.9	7.9	6.4	6.4	6.4	7.1	8.6	8.6	9.7	9.7	10.4
Diameter Mill "D"	12.7	12.7	14.2	12.7	12.7	12.7	12.7	12.7	15.7	19.1	15.8
Depth of Milled Slots "K"	6.4	6.4	7.9	9.7	9.7	9.7	12.7	12.7	12.7	14.2	15.8

Oil outlet diameters ( $d_o$ ) in shaded blocks represent Hydraulic Diameters.

## OIL DISCHARGE CONFIGURATION

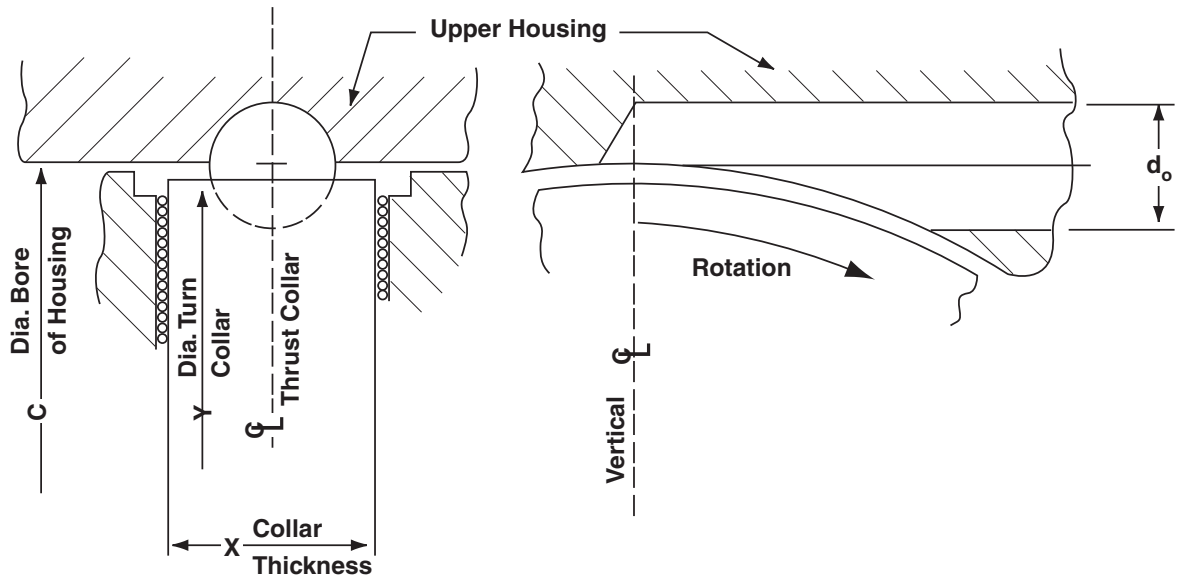

Recommended Discharge Dimensions, Styles J, B & E

### Style J, B and E Bearings—English Units (inches)

Bearing Size	4.0	5.0	6.0	7.0	8.0	9.0	10.5	12.0	13.5	15.0	17.0
Housing Bore "C"	4.375	5.375	6.375	7.375	8.375	9.375	11.000	12.500	14.000	15.500	17.625
Collar Diameter "Y"	4.12	5.12	6.12	7.12	8.12	9.12	10.69	12.19	13.69	15.19	17.25
Collar Thickness "X"	0.88	0.88	1.00	1.25	1.38	1.50	1.75	2.00	2.25	2.50	2.88
Oil Outlet Diameter $d_o$	0.22	0.31	0.44	0.50	0.66	0.81	1.06	1.19	1.31	1.38	1.38

### Style J, B and E Bearings—Metric Conversion (mm)

Bearing Size	101.6	127.0	152.4	177.8	203.2	228.6	266.7	304.8	342.9	381.0	431.8
Housing Bore "C"	111.13	136.53	161.93	187.33	212.73	238.13	279.40	317.50	355.60	393.70	447.68
Collar Diameter "Y"	104.6	130.0	155.4	180.8	206.2	231.6	271.5	309.6	347.7	385.8	438.2
Collar Thickness "X"	22.4	22.4	25.4	31.8	35.1	38.1	44.5	50.8	57.2	63.5	73.2
Oil Outlet Diameter $d_o$	5.6	5.6	11.2	12.7	16.8	20.6	26.9	30.2	33.3	35.1	35.1

### OIL DISCHARGE CONFIGURATION

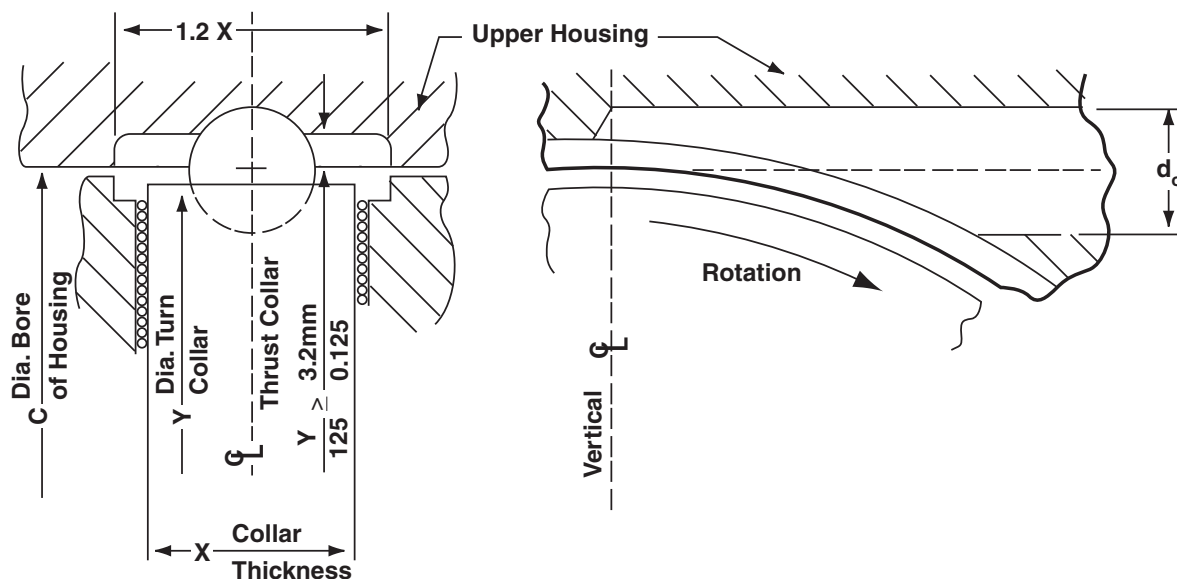

Recommended Discharge Dimensions, Style S

#### Style S Bearings—English Units (inches)

Bearing Size	3	4	5	6.5	7.5	8	9.88	11.12	12.25	13	15	18
Housing Bore "C"	3.250	4.875	5.375	6.750	7.750	8.375	10.125	11.500	12.625	13.500	15.500	18.750
Collar Diameter "Y"	3.12	4.62	5.12	6.62	7.62	8.12	10.00	11.25	12.38	13.19	15.19	18.25
Collar Thickness "X"	0.62	0.88	0.88	1.00	1.12	1.38	1.50	1.75	2.00	2.25	2.50	3.00
Oil Outlet Diameter $d_o$	0.19	0.28	0.47	0.56	0.62	0.81	0.88	0.88	0.94	1.09	1.25	1.44

#### Style S Bearings—Metric Conversions (mm)

Bearing Size	76	102	127	165	191	203	251	283	311	330	381	457
Housing Bore "C"	82.55	123.83	136.53	171.45	196.53	212.73	257.18	292.10	320.68	342.90	393.70	476.25
Collar Diameter "Y"	79.3	117.3	130.1	168.1	193.5	206.3	254.0	285.8	314.5	335.0	385.8	463.6
Collar Thickness "X"	15.8	22.4	22.4	25.4	28.5	35.1	38.1	44.5	50.8	57.2	63.5	76.2
Oil Outlet Diameter $d_o$	4.8	7.1	11.9	14.2	15.7	20.6	22.4	22.4	23.9	27.7	31.8	36.6

## INSTRUMENTATION

### Temperature Measurement

Changes in load, shaft speed, oil flow, oil inlet temperature, or bearing surface finish can affect bearing surface temperatures. At excessively high temperatures, the shoe babbitt metal is subject to wiping, which causes bearing failure.

Consequently, for critical applications, we recommend using shoes with built-in temperature sensors so you can monitor actual metal temperatures under all operating conditions.

Either thermocouples (TCs)

or resistance temperature detectors (RTDs) can be installed in the shoe body near the shoe body/babbitt interface. See figure below for Kingsbury's recommended location. See page 52 "Temperature Detector Location" for further discussion.

### Thrust Measurement

If your bearing is subject to critically high loads, continual thrust measurement will give you a vital indication of machine and bearing condition. To measure thrust, we can install a strain gauge load cell in one or more of the

upper leveling plates or thrust shoe.

This load cell is simply a steel column which is stressed in compression under load. Wire resistant strain gages mounted on the column register the strain. Since the strain is directly proportional to load, instrument readout can be calibrated to show thrust directly.

Each load cell is installed so that the bearing shoe rests directly on top of it, or if installed in the thrust shoe, the shoe support is replaced by the load cell and contacts the upper leveling plate.

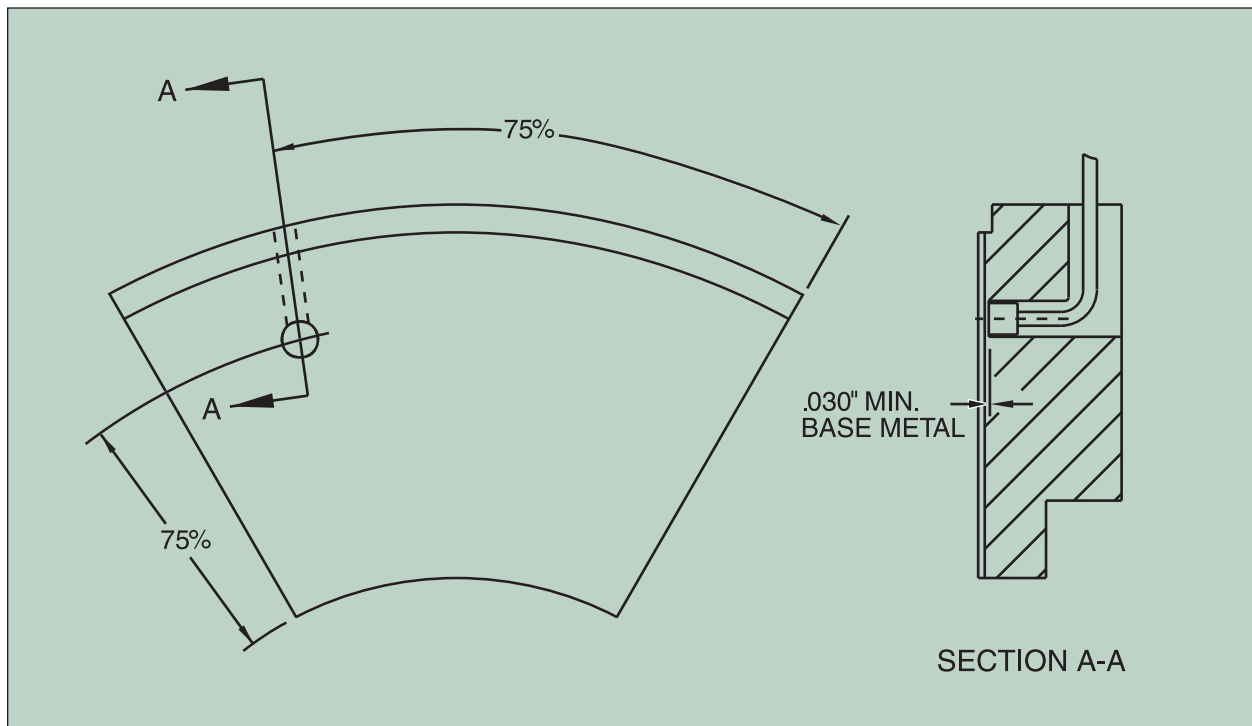

These arrangements allow thrust measurements within 2%, if all shoes are instrumented. However, we have found that you can obtain satisfactory accuracy for most thrust measurement requirements with one or two load cells per bearing.

*Note: Mechanical friction in the leveling plates precludes perfect load equalization.*

You can purchase a complete thrust measurement system from us, or you can order an of the following system parts:

- Load cells
- Readout instruments
- Standard stuffing boxes for sealing load cell lead wires at the bearing housing
- Oil-tight junction box
- Cables for connecting the junction box to the readout instrument

### Special Design Features

- Load cells are individually calibrated in leveling plates or thrust shoes, numbered serially, and provided with calibration data.
- Load cell sensitivity and impedance are standardized to permit the consecutive reading of several load cells by one readout instrument.
- Standardization also permits connection of several load

cells in series or parallel so that multiple load cells can be read with a single-channel readout instrument.

- Standardization is achieved by providing each load cell with compensating resistances soldered into a printed circuit board, furnished with an edge connector base. The printed circuit boards can be mounted in the junction box, or in the readout instrument if space permits.
- Metals used to make the load cell are stressed well below their  $10^{10}$  cycle endurance limit, thereby assuring a life span equivalent to that of the bearing.
- Positive environmental sealing keeps load cell performance from deteriorating over time.
- Abrasion-resistant, Teflon<sup>®</sup> wrapped and fused cable permits permanent immersion in petroleum-based lubricants.
- Explosion-proof junction box construction is available.
- Analog readout instruments are standard, but other types are available upon request. Readout instruments can be equipped with two adjustable set points.

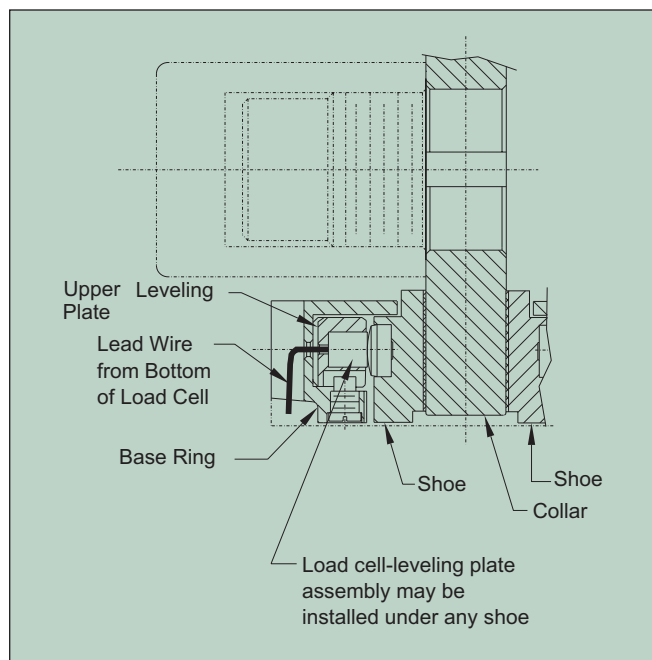

**Typical Load Cell Installation**

# SHAFT AXIAL POSITION INDICATION

If knowing the exact axial position of your machine shaft is important, we can incorporate a proximity measuring system into our standard equalizing thrust bearing. A proximity probe inserted through the housing, base ring, and lower leveling plates detects any thrust collar movement.

## Recommended Locations for Proximity Probes (Style J, B, & E Bearings)

Bearing Size	mm	
	B	Probe Dia.
102 4.0	Not Applicable	
127 5.0	98.7 3.89	6.4 0.25
152 6.0	117.7 4.62	6.4 0.25
178 7.0	136.5 5.38	6.4 0.25
203 8.0	154.8 6.09	6.4 0.25
229 9.0	173.8 6.84	6.4 0.25
267 10.5	202.4 7.97	9.6 0.38
305 12.0	231.0 9.09	9.6 0.38
343 13.5	259.2 9.09	9.6 0.38
381 15.0	287.4 11.31	9.6 0.38
432 17.0	326.2 12.84	9.6 0.38

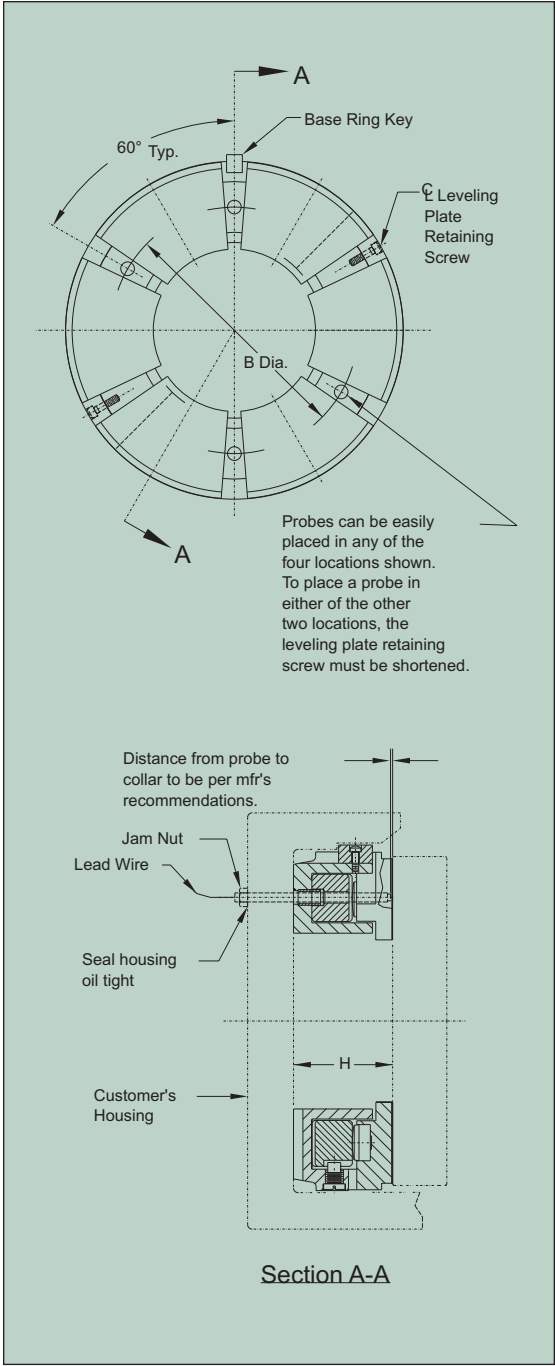



# SHOE RETENTION

All styles of bearings in this catalog can be furnished with retained shoes. We recommend that you use retained thrust shoes any time the bearing will be installed fully assembled or handled frequently.

*Note: The retention feature is for handling and is not intended to hold the shoes in operation. Refer to page 51.*

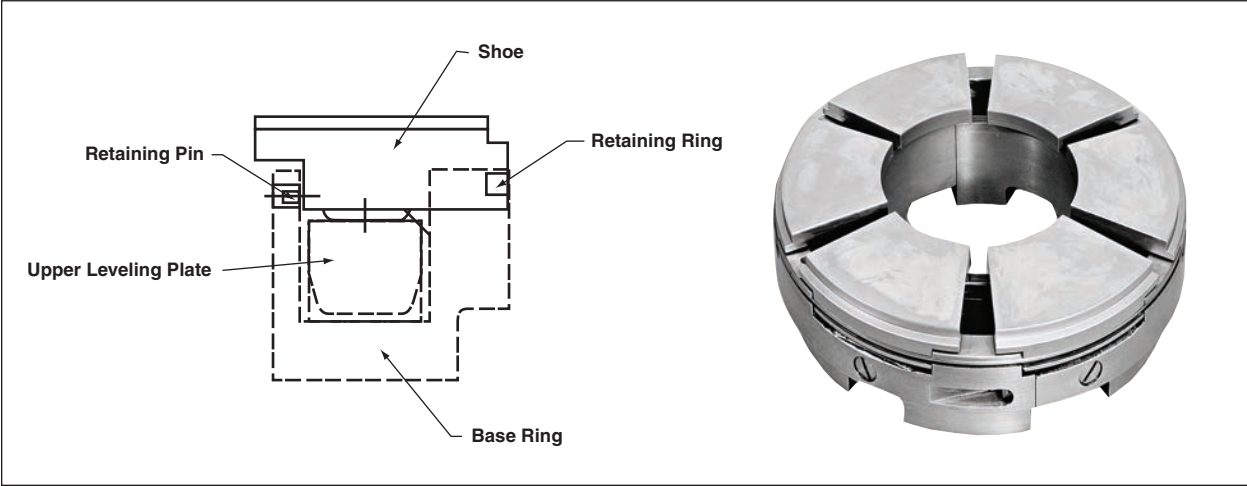

Shoe Retention by Retaining Ring

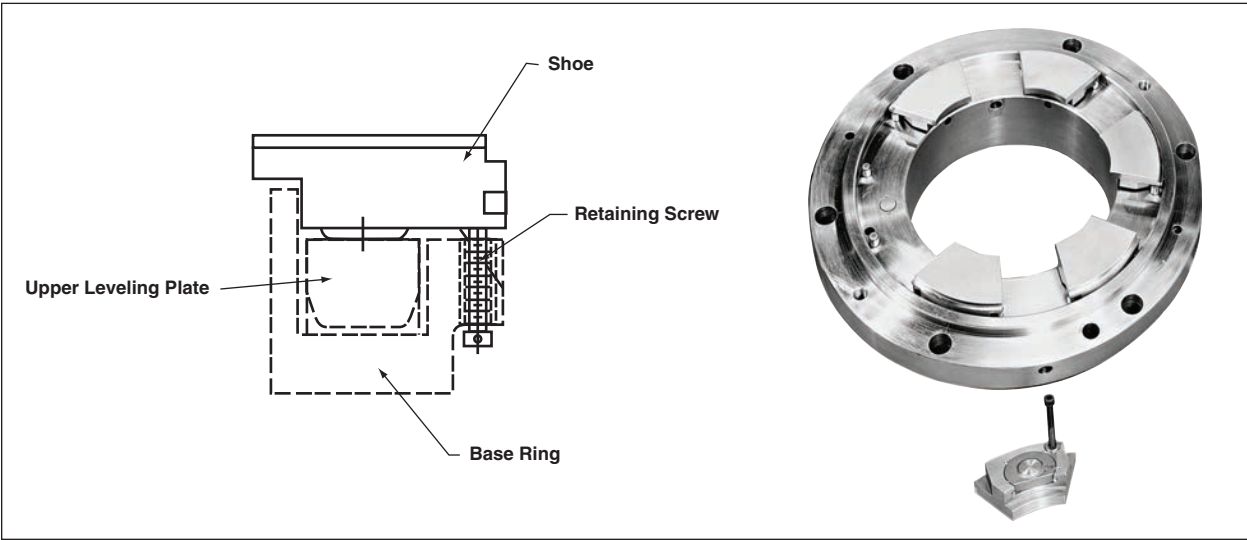

Shoe Retention by Retaining Screw

# TYPICAL ARRANGEMENTS

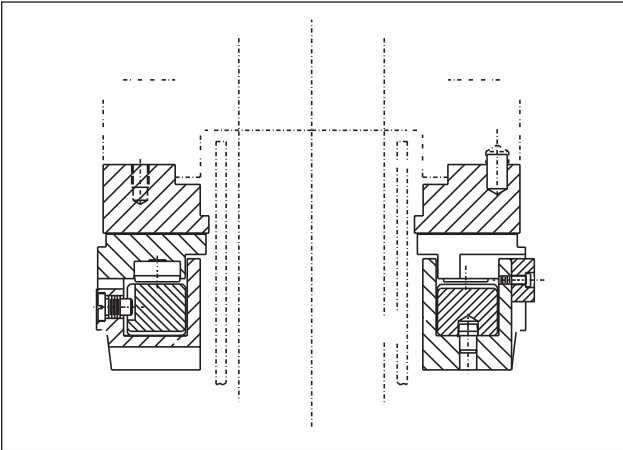

Single Thrust Bearing in Vertical Application

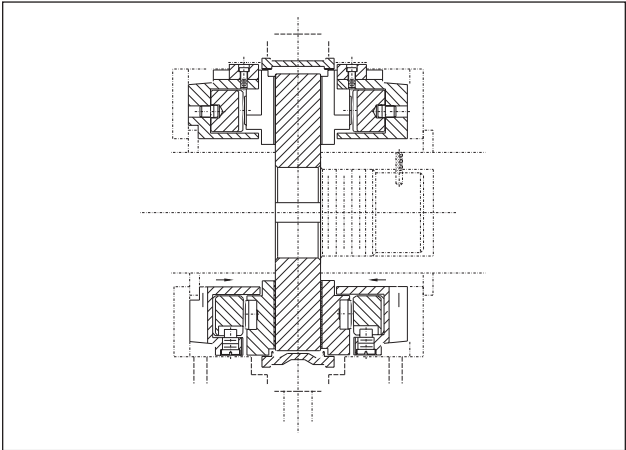

Standard Double Thrust Bearing with Oil Control Ring

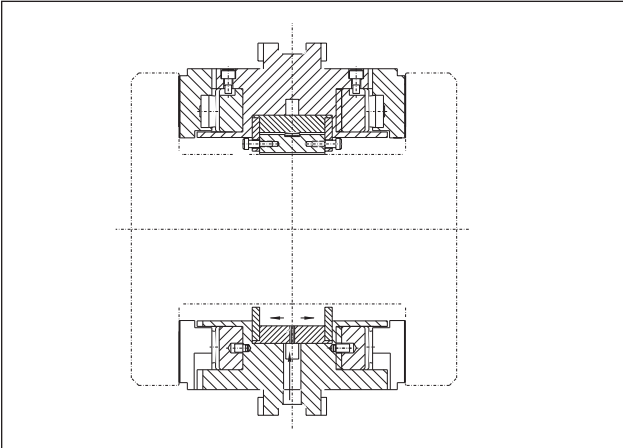

Combination Bearing with Pivoted Thrust and Journal Shoes

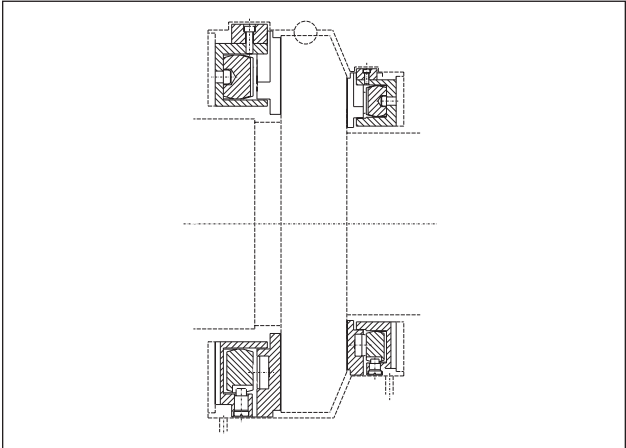

Double Thrust Bearing with Different Size Elements

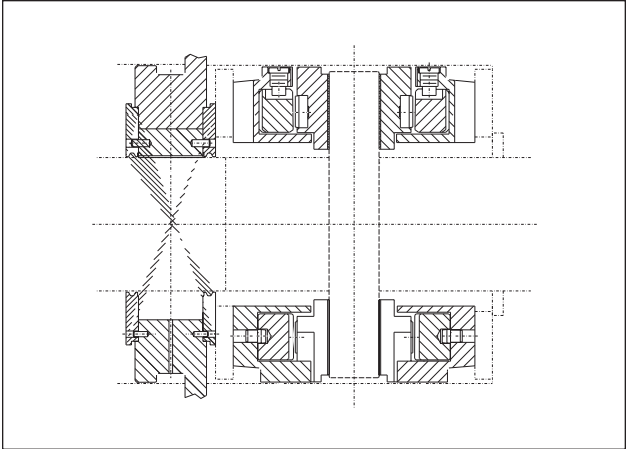

Double Thrust Bearing with Tilting Shoe Journal Bearing

## NOTES ON SELECTING KINGSBURY THRUST BEARINGS

### API Ratings

The thrust bearing ratings given in the charts comply with API specifications for thrust bearing selection, i.e., all loads listed are equal to or less than one half of the ultimate capacity.

### Slack Side Load Capacity & Flow

Load capacity is related to shoe temperature which is influenced by oil flow. The rated loads listed in the charts are based on recommended flow values to the loaded bearing. In machines where load can reverse and apply full force on the normally slack bearing, an equal amount of oil flow is required to the “slack side.”

Power loss varies with oil flow. The case of equal rated load capacity and flow to both bearing sides results in the highest power loss. If design loads are less than the bearing ratings, flow requirements can be lowered with a resulting reduction in power loss. To achieve the optimum reduction in power loss, load and slack-side flows can be

sized proportionately for normal and reverse design loads.

Time is required for operating shoe temperatures to climb to steady state values. When the reverse load is of very short duration, or when there is little or no reverse load, slack side flows can be reduced to as low as 20% of rated values resulting in the lowest possible power loss and flow requirements.

### Endplay

Endplay recommendations presented in this catalog are a generic guideline to cover a wide range of applications. Special cases such as very high speeds, extreme ambient conditions, external axial vibration, etc., may require special consideration and recommendations. Please contact your Kingsbury Sales Engineer for situations not addressed by this catalog.

### Shoe Retention

Standard thrust bearings are designed with features to hold the shoes in place so the bearings do not fall apart during handling and assembly. This feature is not the same as the housing design which is required to retain the shoes during operation. If the housing does not serve this purpose, e.g., in the case of a retrofit application, it is impor-

tant to consult Kingsbury so that a shoe retention design can be engineered to be best-suited for your application.

### Shock Loads

Thrust bearings contain several contact areas which allow shoe pivot, equalizing and misalignment features. These features are conservatively designed for the rated loads listed in this catalog as well as usual momentary or adverse conditions that may be encountered in most machine operation. Special designs and parts are available for more severe requirements such as shock loads or earthquake (seismic) design criteria. Contact your Kingsbury Sales Engineer to discuss these applications.

## GENERAL INFORMATION ON THRUST BEARINGS

### Hydrodynamic Principle

Because of its adhesion, oil is dragged by the rotating member so as to form a wedge-shaped film between the bearing surfaces. In a flooded bearing, oil is provided to the rotating surface by flooding the space between shoes.

### Catalog Curves

Power loss and shoe temperature curves are provided to allow a quick, reasonably accurate estimation of loss and temperature for the various bearings available in this catalog. To accomplish this, curves have been reduced in quantity to average values for a variety of configurations. This results in a possible 5% variation which is a reasonably good estimate for design purposes. If your estimations fall too close to design limits, our engineering department can assist with your particular selection, application, and criteria.

### Temperature Detector Location

The most accurate measurement of surface temperature is obtained with the detector installed in the babbitt. However, babbitt is a soft

material and can deform over time under hydrodynamic film forces resulting in a dimple in the surface. The detector may read inaccurate values because of the local distortion and can be damaged by the forces. Unsupported babbitt is also subject to fatigue which can lead to more severe damage and eventual failure.

Such problems are prevented by installing the detector in the shoe body assuring there is base metal above the detector hole to support the babbitt. There is only a small difference in temperature which we can relate to surface temperature and set alarm and trip appropriately to accommodate the slight change in depth. Considering the problems associated with installation in the babbitt, installation in the shoe body provides a more effective level of protection and is recommended by Kingsbury.

### Pressure And Flow Orifice

For flow control, Kingsbury recommends an upstream orifice in the line to each bearing (loaded thrust, slack thrust, and each journal). If these are external to the housing, adjustments to flow can be made without disassembling and machining the bearings or bearing casings. Such adjustments may be required to optimize flow for bearing temperature or

power loss, or to increase flow in cases of upgrades.

Orifice sizing is a straightforward procedure. The major pressure drops consist of the pressure drop through the upstream orifice and the drop through the bearing. The recommended flow for the bearing depends on operating conditions. For lower speeds, less flow is required and, since pressure is proportional to flow, less pressure is required at the bearing. The required pressure at the bearings ranges from .25 atmosphere for flows at the low speed end of the charts, to .5 atmosphere at mid range, to 1.0 atmosphere at the high speed end. Each upstream orifice can be sized to drop the system supply pressure to the pressure required at each bearing.

### Alarm & Shutdown Limits For Temperature

Temperatures on the order of 160° C cause plastic flow of the babbitt. Maximum temperatures are conservatively limited to 135° C. Allowing 8° C for alarm and 15° C for trip settings, maximum operating babbitt temperature is 120° C. It is important to note that alarm and trip are set relative to normal design temperatures. Specifically, if the design temperature is 85° C, the trip should be set at 100° C, not 120° C.

In addition to the bearing,

consideration has to be given to the temperature limitations of the lubricant. Consult the lubricant supplier for information on the lubricant's limitation.

### Maximum Speeds

It is difficult to set a rule of thumb on maximum speed because of the many factors that affect the limits. The curves and charts listed in this catalog are purposely limited to conservative speeds. The bearings are suitable for higher speeds, but may require special consideration with regards to shoe material, oil flow, flow paths, and housing configuration. Therefore, if your application exceeds the speeds shown in the charts, please contact us for assistance.

### Options

In order to achieve the best performance from a bearing, it should be optimized for one direction of rotation. Significant gains in performance (e.g., lower operating temperatures) can be attained by offsetting the pivot or using the leading edge groove (LEG) thrust bearing. The LEG bearing is a direct-lubrication bearing which requires significantly less oil and thereby reduces power losses. Bearings designed this way can still operate in reverse with approximately 60% of the load capacity of the forward direction depending on the speed. Consult Kingsbury's LEG Catalog for further details

### Backing Material

Data is presented in the catalog for steel and chrome copper shoes which are suitable for most applications. Other materials are available for special applications.

## INQUIRY CHECKLIST

To help you select the proper thrust bearings, please provide the following information about your applications. For applications outside the standard range, or for special features not listed in this catalog, please consult your Kingsbury Sales Engineer directly. In an effort to continually improve quality and performance, Kingsbury reserves the right to upgrade materials and/or design.

### THRUST BEARINGS

- Type of application
- Thrust load on active side
- Reverse thrust, if any
- Shaft speed
- Shaft diameter at ID of bearing
- Oil type - viscosity
- Oil inlet temperature
- Maximum shoe temperature requirements, if any

### Additional equipment/options

- Instrumentation - type, quantity, location
- Filler plates - thickness
- Shims - thickness
- Collar - bore and key size
- Special specifications - Military, Industrial, API, etc.
- Any other requirements

# KINGSBURY REPAIR & SERVICE

## Spare Parts

When a Kingsbury thrust bearing is chosen correctly, aligned properly, and supplied with clean oil, its life span should be at least that of the machine. Accidents occur, however, so we recommend stocking the following spare parts:

- One set of shoes,
- One collar, and
- One set of oil seal rings.

# FIELD SERVICE

If a bearing problem develops in the field that requires on-site consultation or service work, Kingsbury can provide Field Service Engineers. Contact our office in Philadelphia, PA, for details regarding such service.

# FACTORY REWORK

Kingsbury provides inspection and rework on all manufacturers' brands and types of bearings that have been in service. Bearing parts are repaired or replaced to restore the bearing to its original operating capabilities.

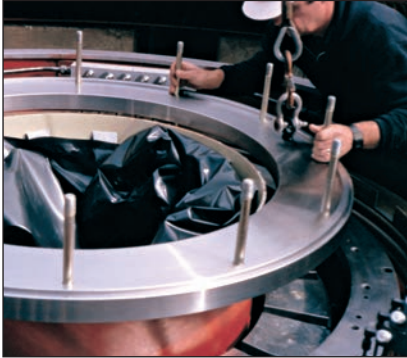
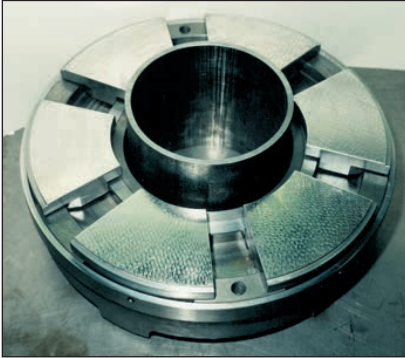

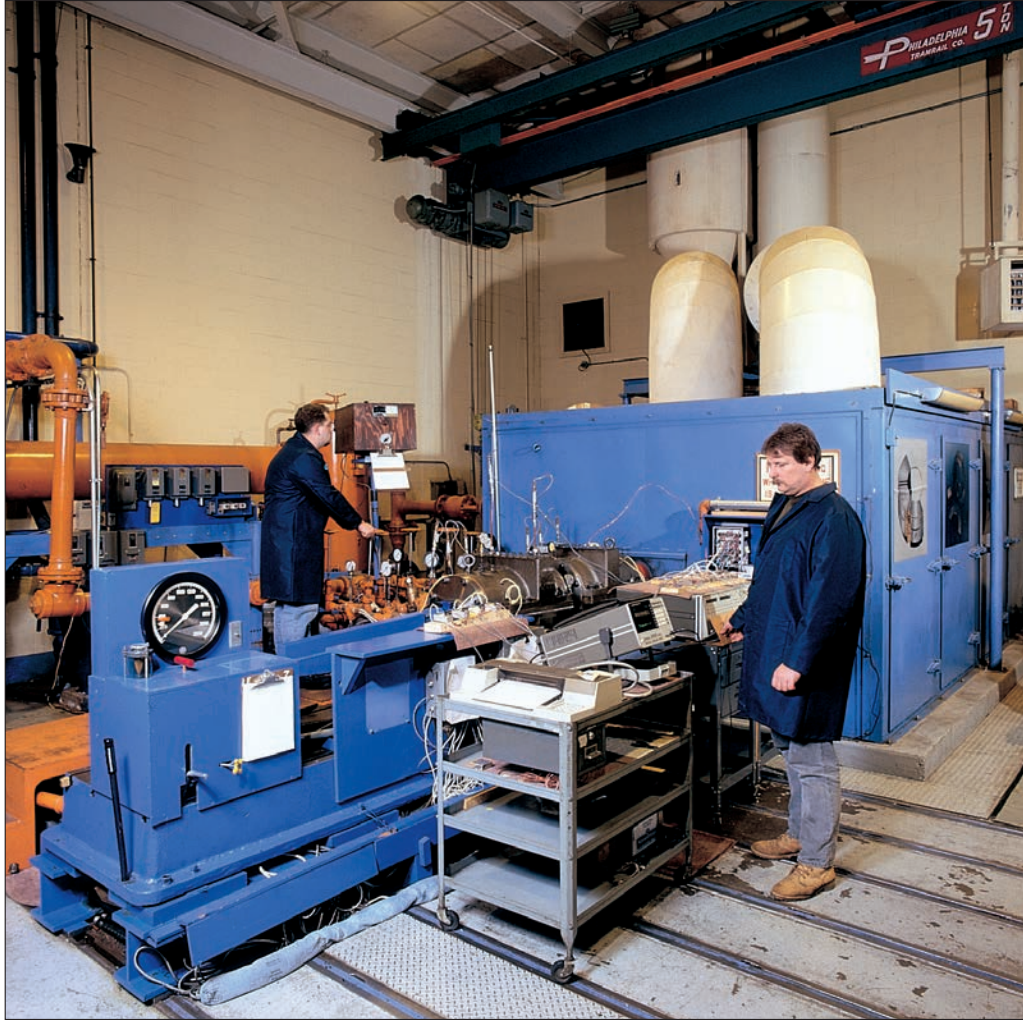

Gas turbine driven, high speed, horizontal thrust and journal bearing test rig.

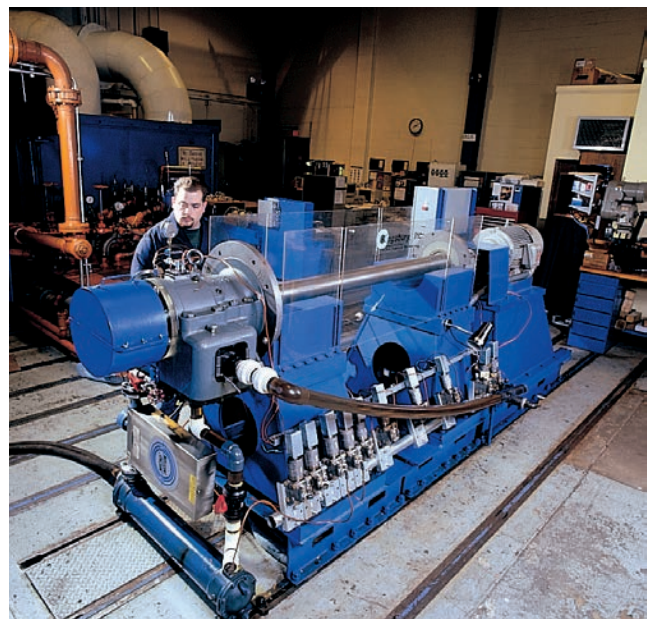

Kingsbury's dedicated CH Bearing test stand validates performance specifications for this specialized self-contained thrust and journal combination.



The Best Support In The Business.

10385 Drummond Road  
Philadelphia, PA 19154 USA  
Telephone: 1-215-824-4000  
Fax: 1-215-824-4999  
[www.kingsbury.com](http://www.kingsbury.com)