

Fixed Profile

KN-SERIES PLAIN JOURNAL BEARINGS

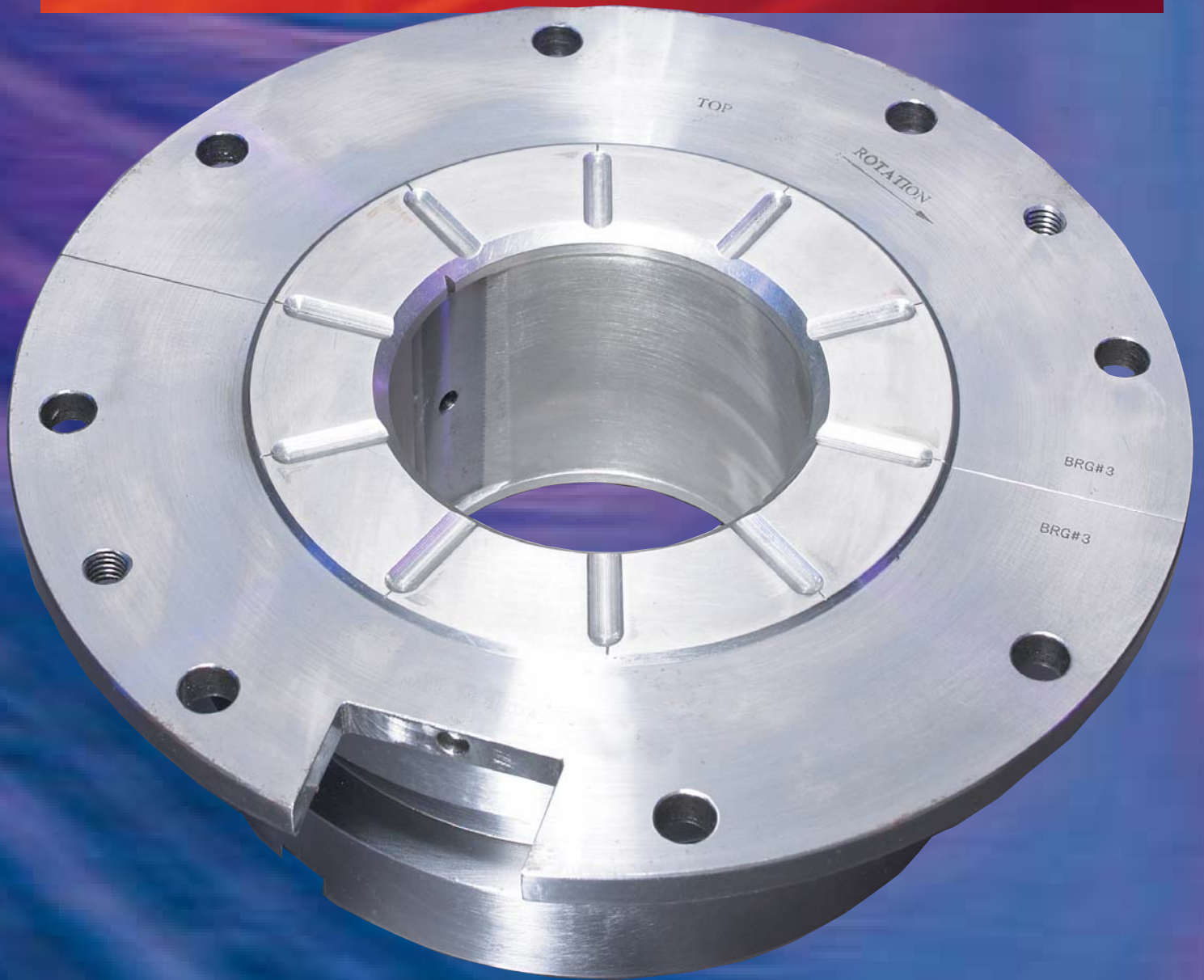

KN-Series Fixed Profile

Description

Kingsbury now offers a standard line of plain journal bearings in addition to our proven tilting pad design. KN thick-walled metric bearings are designed for pressure oil-lubricated rotating machinery such as turbines, pumps and gears. Power ranges typically at 1MW and operate at sliding speeds of 5m/s to 90 m/s. A wide variety of sizes and proportions are available in shaft sizes of up to 710 mm. Standard designs can be customized for individual applications to suit any shaft size. For shaft sizes above 710 mm, bearings are custom made to your specifications. Kingsbury will also manufacture bearings to customer supplied drawings and specifications.



Benefits & Features

Our standard sizes and designs make selection easy and efficient. All standard parts are babbitt-lined, steel-backed and manufactured to ISO standards. Our standard babbitt material is ASTM: B23 Grade 2, but many other grades and types are available. Thrust capacity up to 1.7 MPa times the active thrust area can be provided on KN thick wall bearings or by separate thrust washers. For higher loads and faster sliding speeds, tilting pad bearings should be considered. For the most part, these plain journal bearings are perfect for lower speed, moderate load applications and provide a reliable alternative to more expensive bearing styles. See Table 1 for selection information.

Polymer linings are available to extend performance limits, to operate with non-oil lubricants such as water, or to be used in harsh environments.

Lubrication Requirements

These bearings require a continuous supply of high quality lubricating oil. For most applications, we recommend ISO VG 32, 46 or 68 (without EP additives) supplied at 45°C to 55°C and filtered to 25 microns or better. The oil both lubricates and removes the heat that is generated within the oil film. The oil flow rate for plain bearings is a function of speed, load, clearance, and viscosity.

The inlet pressure to the bearing has little effect on the flow rate and only needs to be 0.25 bar but can be higher. To increase the flow rate and lower bearing temperatures, the bore profile should be modified. See Table 1. Kingsbury's state-of-the-art computer calculation models can accurately predict performance for any of the different profiles listed in the table.

Clearances

The clearance between the bearing and the shaft is a critical parameter for successful performance and expected operation. The clearance must be large enough to allow for thermal expansion and provide space for the hydrodynamic oil film. In general, tighter clearance promotes stability characteristics, while looser clearance provides for lower oil film temperatures. Often the bearing designer must balance these competing parameters. Figure 1 shows Kingsbury's recommended *minimum* clearance. The maximum clearance is found by adding the bearing bore tolerance (usually H7) to the shaft tolerance (H6.) The shaft size can be found by subtracting the minimum clearance value from the nominal bearing size.

Example:

150 mm bearing operating at 75 m/sec

Min clearance = 1.6 μ m x 150 = 0.24mm (Reference Figure 1)

Shaft = 150 - 0.24 = 149.76 H6









Bearing = 150 H7

Diameter & Length

Shaft diameter is usually fixed by the machine's torque or stability considerations. For the shaft, we recommend an H6 tolerance with a surface finish of Ra 0.4 μ m. Load capacity varies with bearing lengths for which there are 3 standard ratios of length to diameter. Other ratios can also be supplied to optimize performance. As an initial guide, radial load divided by projected area should not exceed 3.8 MPa, therefore it is advisable to design below this limit. See Table 1.

Note: Projected area can be found by multiplying the bearing's length times the diameter.

Table 1: Bearing Profiles

Bearing Type	Relative Complexity	Relative Cost	Reversible	Sensitivity To Load Angle ¹	Typical Preload	Relative Stability	Relative Pad Temp	Relative Load Capacity ² Typ. Unit Load, MPa	Typical Speed Limit ³	Notes
 Cylindrical	1	1	Yes	2	0	1	5	5 3.5	30	Simple, for lower speed apps. Unsuitable for light loads
 Elliptical	2	2	Yes	2	0.3-0.5	2	4	5 3.5	45	For moderate speeds/loads. Low horizontal stiffness.
 OS Halves	3	2	No	2	0.25-0.4	2-3	3	5 3.8	45	Better stability/temps than elliptical.
 Symmetrical 4-Lobe	4	3	Yes	5	0.7 - 0.8	4	2	1 1.7	75	Good for high speeds, light loads. Tighter clearance at light loads.
 Canted 4-Lobe	4	3	No	5	0.45-0.55	4	2	3 2.7	90	For high-speed, moderate load apps.
 Symmetrical 3-Lobe	5	3	Yes	4	0.6-0.7	3	2	2 2.4	60	Better load capacity than sym. 4-lobe. Not well suited to split design.
 Canted 3-Lobe	5	3	No	3	0.4-0.5	3	2	4 3.3	75	Better load capacity than canted 4-lobe. Not well suited to split design.
 Tilt-Pad	3	5	Yes	1	0.1-0.5	5	1	5 3.8	150	Good for high speeds, high loads. Stable, low pad temps, many options.

Footnotes: On a scale of 1-5, 1 = Low, 5 = High ¹ Except at light loads ² Load capacity depends on speed ³ Speed limit depends on shaft weight

Installation And Tolerances

Proper installation is critical to optimal performance. We recommend bearing housing bores to be machined to an H7 tolerance. To insure proper installation, bearings are supplied with zero or a slight positive free spread. Free spread varies with shaft diameter and wall thickness.

KN bearings are supplied with an anti-rotation and alignment dowel pin for proper location within the bearing housing. The pin should be located in a milled slot at the joint line for ease of assembly. The bearing must be located so that the load angle is $90^\circ \pm 30^\circ$ to the bearing split line in most cases. Three lobe and four lobe bearings should be closely reviewed for proper orientation relative to the load vector.

Bearing Temperature And Measurement

Bearing problems and failures are in most cases reflected by elevated oil film temperatures. Normal operation creates heat from the work being done by the supporting oil film. This temperature can be predicted by Kingsbury's state of the art computer calculation models. By measuring the bearings surface temperature, very close to the oil film, one can determine if the bearing is operating properly. If the normal temperatures are exceeded, the machine can be stopped before failure occurs.

Kingsbury recommends that the temperature sensor be installed along the load angle or 10° - 20° downstream of the load angle toward the trailing edge. Maximum design running temperature should be 115°C or less. Alarm settings should be set to 8°C above normal or expected values and trip settings 7°C above alarm. In no case should the maximum trip temperature be above 130°C .

Bore Profiles And Dynamic Characteristics

Special bore profiles are available for stability in high speed, low load situations and to reduce the bearings temperature. Table 1 provides a detailed comparison of the advantages and disadvantages for different types of bore profiles that are available. In most cases, a decision must be made between cost and performance. Information about how the bearing characteristics affect the system stability is important with regard to this decision. Kingsbury can provide stiffness and damping values for any of these bearing types based on your application.

Figure 1: Clearance Vs. Speed

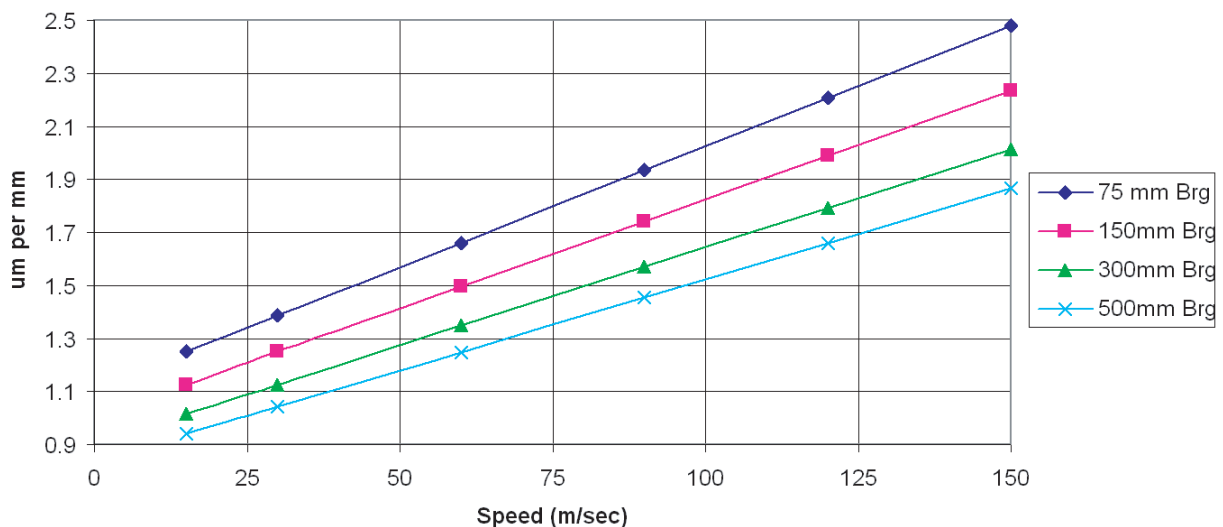

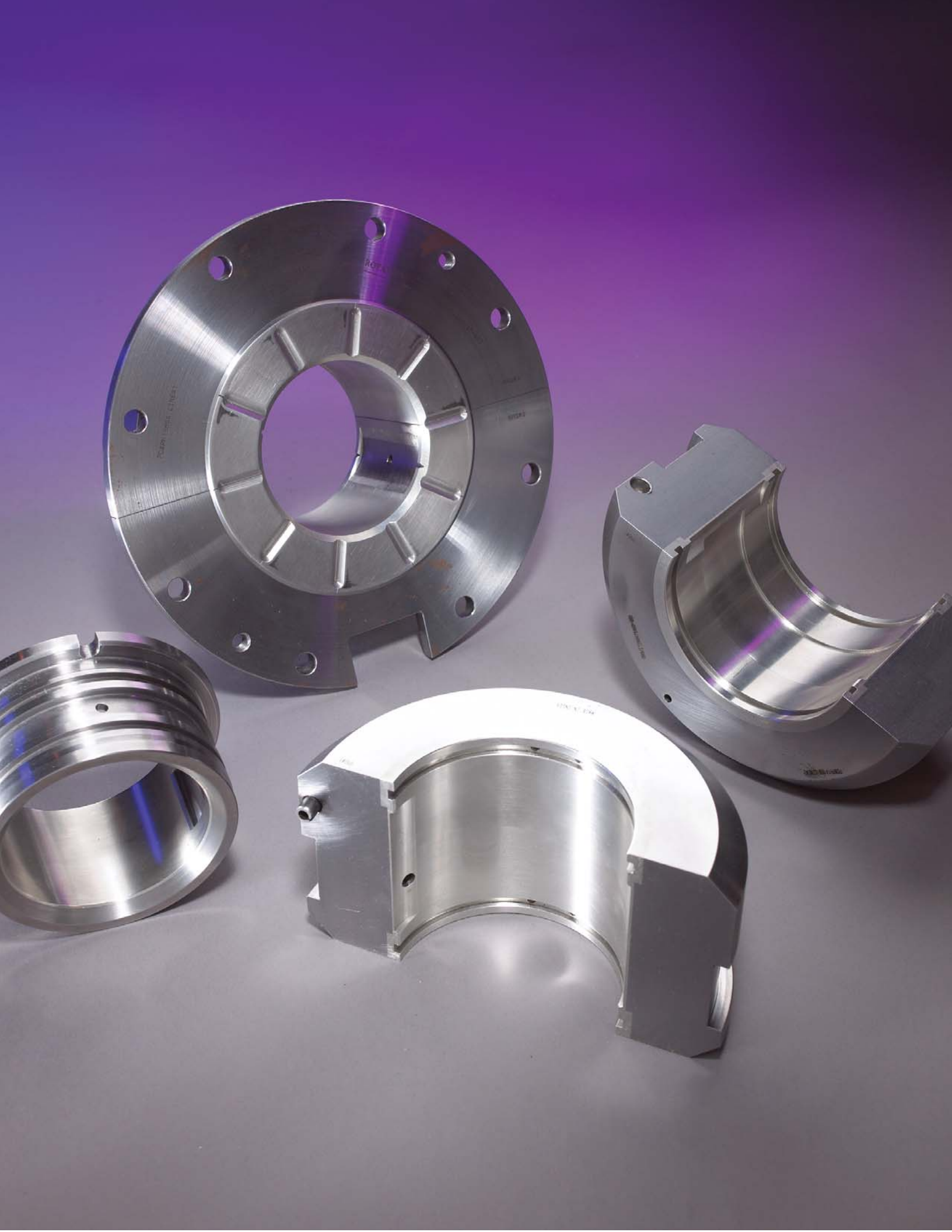

KN-SERIES PLAIN BEARING STYLES

Plain Bearing In Halves (KNG)

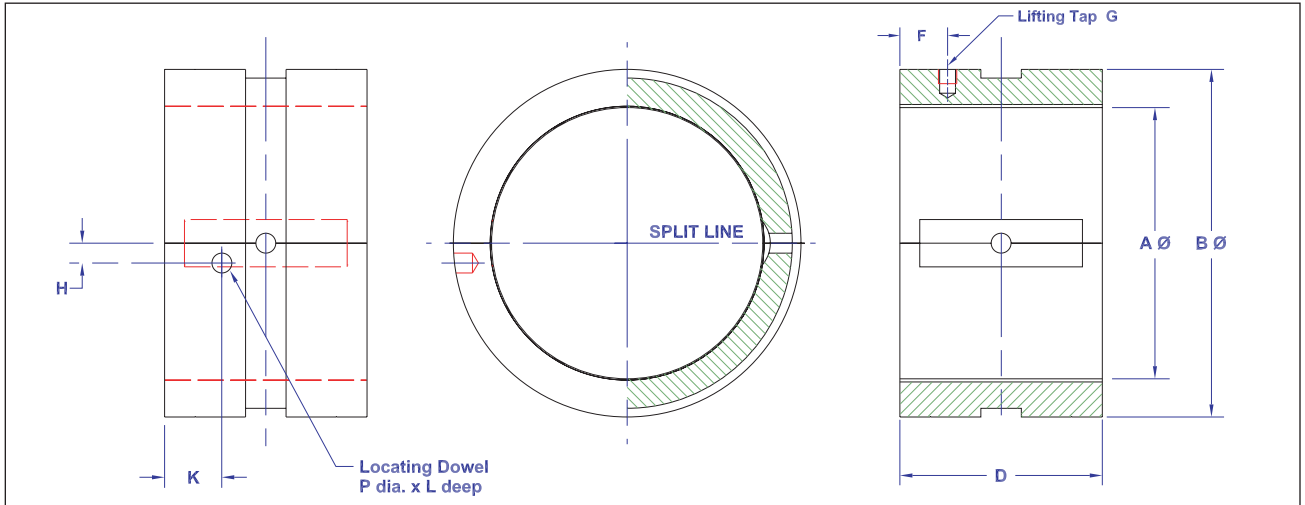

Plain Bearing In Halves With Flanges (KNF)

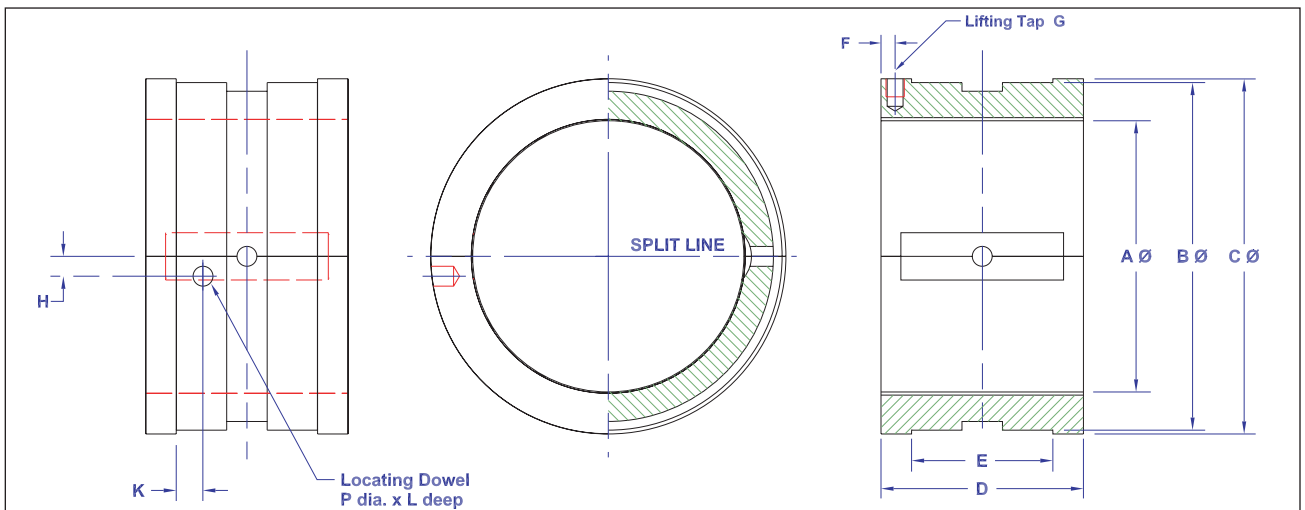

Plain Bearing In Halves With Flanges And Locating Faces (KNFL)

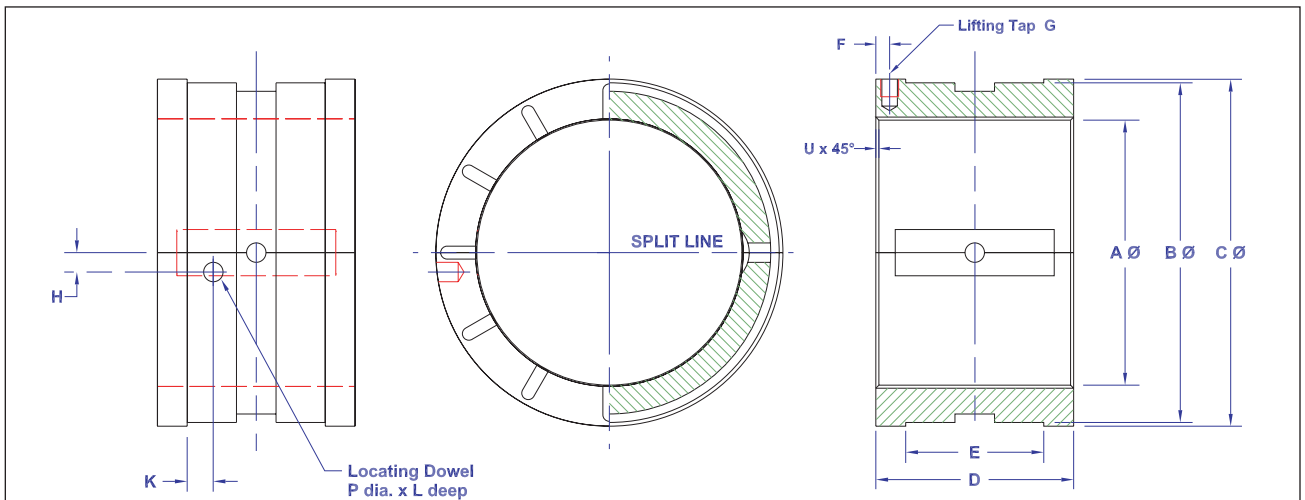

KN-SERIES

THICK WALL BEARINGS L/D = 0.5

Note: Standard dimensions are shown. Please contact Kingsbury's engineering department for non-standard, make-to-print or English dimensions. Custom L/D ratios are also available on request.

Size Plain bearing in Halves (KNG)	Size Plain bearing in Halves w/ Flanges (KNF)	Size Plain bearing in Halves, Flanges, Loc. Faces (KNFT)	A Bore	B		C	D	E	P	J	K	L	G	U
				Tol										
050 KNG 025	050 KNF 025	050 KNFT 025	50	65		70	25	17	4	6	4	3		3
052 KNG 025	052 KNF 025	052 KNFT 025	52	65		70	25	17	4	6	4	3		3
055 KNG 025	055 KNF 025	055 KNFT 025	55	70		75	25	17	4	6	4	3		3
056 KNG 030	056 KNF 030	056 KNFT 030	56	70		75	30	20	4	7	5	3		3
058 KNG 030	058 KNF 030	058 KNFT 030	58	75	m6	80	30	20	4	7	5	3		3
060 KNG 030	060 KNF 030	060 KNFT 030	60	80		85	30	20	4	7	5	3		3
063 KNG 030	063 KNF 030	063 KNFT 030	63	80		85	30	20	4	7	5	3		3
065 KNG 030	065 KNF 030	065 KNFT 030	65	85		90	30	20	4	7	5	3		3
068 KNG 035	068 KNF 035	068 KNFT 035	68	85		90	35	25	4	8	4	3		3
070 KNG 035	070 KNF 035	070 KNFT 035	70	90	m6	95	35	25	4	8	4	3		3
072 KNG 035	072 KNF 035	072 KNFT 035	72	90		95	35	25	4	8	4	3		3
075 KNG 035	075 KNF 035	075 KNFT 035	76	95		101	35	25	4	8	4	3		3
080 KNG 040	080 KNF 040	080 KNFT 040	80	105		111	40	30	4	10	5	3		3
085 KNG 040	085 KNF 040	085 KNFT 040	85	110		116	40	30	5	10	5	4		3
090 KNG 045	090 KNF 045	090 KNFT 045	90	115	m6	121	45	30	5	10	5	4		3
095 KNG 045	095 KNF 045	095 KNFT 045	95	120	m6	126	45	30	5	10	5	4		3
100 KNG 050	100 KNF 050	100 KNFT 050	100	130	k6	136	50	35	6	13	6	5		3
105 KNG 050	105 KNF 050	105 KNFT 050	105	135		142	50	35	6	13	6	5		3
110 KNG 055	110 KNF 055	110 KNFT 055	110	140		147	55	40	6	13	7	5		3
120 KNG 060	120 KNF 060	120 KNFT 060	120	155		162	60	40	7	13	7	6		3
125 KNG 060	125 KNF 060	125 KNFT 060	125	160		168	60	40	7	13	7	6		4
130 KNG 065	130 KNF 065	130 KNFT 065	130	170		178	65	45	7	16	8	6		4
140 KNG 070	140 KNF 070	140 KNFT 070	140	180		188	70	50	7	16	8	6		4
150 KNG 075	150 KNF 075	150 KNFT 175	150	195		203	75	50	9	20	8	8		4
160 KNG 080	160 KNF 080	160 KNFT 080	160	205	k6	213	80	55	9	20	10	8		4
170 KNG 085	170 KNF 085	170 KNFT 085	170	220		228	85	60	9	20	10	8		5
180 KNG 090	180 KNF 090	180 KNFT 090	180	230		238	90	65	9	20	12	8		5
190 KNG 095	190 KNF 095	190 KNFT 095	190	245		255	95	65	11	25	12	10		5
200 KNG 100	200 KNF 100	200 KNFT 100	200	260		270	100	70	11	25	12	10		5
210 KNG 105	210 KNF 105	210 KNFT 105	210	270	k6	280	105	75	11	25	12	10		8
225 KNG 110	225 KNF 110	225 KNFT 110	225	290	k6	300	110	75	11	30	12	10	M8	8
235 KNG 115	235 KNF 115	235 KNFT 115	235	305	js6	315	115	80	11	30	12	10	M8	8
250 KNG 125	250 KNF 125	250 KNFT 125	250	325		337	125	85	13	35	16	15	M8M8	10
265 KNG 130	265 KNF 130	265 KNFT 130	265	345		357	130	90	13	35	16	15	M8	10
280 KNG 140	280 KNF 140	280 KNFT 140	280	360		372	140	100	13	40	20	15		10
300 KNG 150	300 KNF 150	300 KNFT 150	300	390		403	150	105	15.3	40	20	18	M10	10
315 KNG 155	315 KNF 155	315 KNFT 155	315	410		425	155	110	15.3	40	20	18	M10	13
335 KNG 165	335 KNF 165	335 KNFT 165	335	435		451	165	115	15.3	50	20	18	M10	13
355 KNG 175	355 KNF 175	355 KNFT 175	355	460		476	175	120	15.3	50	25	18	M10	13
375 KNG 185	375 KNF 185	375 KNFT 185	375	485	js6	501	185	130	17.5	50	25	20	M12	13
400 KNG 200	400 KNF 200	400 KNFT 200	400	515		531	200	140	17.5	60	25	20	M12	13
425 KNG 210	425 KNF 210	425 KNFT 210	425	550		566	210	145	22	60	25	25	M12	16
450 KNG 225	450 KNF 225	450 KNFT 225	450	580		596	225	155	22	70	30	25	M16	16
475 KNG 235	475 KNF 235	475 KNFT 235	475	610		628	235	165	27	70	30	30	M16	16
500 KNG 250	500 KNF 250	500 KNFT 250	500	645	js6	663	250	175	27	70	35	30	M16	16
530 KNG 265	530 KNF 265	530 KNFT 265	530	685		703	265	185	27	70	35	30	M20	20
560 KNG 280	560 KNF 280	560 KNFT 280	560	700		738	280	195	32	80	40	30	M20	20
600 KNG 300	600 KNF 300	600 KNFT 300	600	770		790	300	210	32	80	40	30	M20	20
630 KNG 315	630 KNF 315	630 KNFT 315	630	810		830	315	220	42	90	40	40	M20	24
670 KNG 335	670 KNF 335	670 KNFT 336	670	860	js6	880	335	235	42	90	45	40	M24	24
710 KNG 335	710 KNF 335	710 KNFT 355	710	910	js6	930	355	250	42	100	50	40	M24	28

KN-SERIES

THICK WALL BEARINGS L/D = 0.75

Note: Standard dimensions are shown. Please contact Kingsbury's engineering department for non-standard, make-to-print or English dimensions. Custom L/D ratios are also available on request.

Size Plain bearing in Halves (KNG)	Size Plain bearing in Halves w/ Flanges (KNF)	Size Plain bearing in Halves, Flanges, Loc. Faces (KNFT)	A Bore	B		C	D	E	P	J	K	L	G	U
					Tol									
050 KNG 035	050 KNF 035	050 KNFT 035	50	65		70	35	24	4	10	5	3		4
052 KNG 040	052 KNF 040	052 KNFT 035	52	65		70	40	30	4	10	5	3		4
055 KNG 040	055 KNF 040	055 KNFT 040	55	70		75	40	30	4	10	6	3		4
056 KNG 040	056 KNF 040	056 KNFT 040	56	70		75	40	30	4	10	6	3		4
058 KNG 045	058 KNF 045	058 KNFT 045	58	75	m6	80	45	30	4	10	6	3		4
060 KNG 045	060 KNF 045	060 KNFT 045	60	80		85	45	30	4	10	6	4		4
063 KNG 045	063 KNF 045	063 KNFT 045	63	80		85	45	30	4	10	6	4		4
065 KNG 050	065 KNF 050	065 KNFT 050	65	85		90	50	35	5	12	6	4		4
068 KNG 050	068 KNF 050	068 KNFT 050	68	85		90	50	35	5	12	6	4		4
070 KNG 050	070 KNF 050	070 KNFT 050	70	90	m6	95	50	35	5	12	6	4		4
072 KNG 050	072 KNF 050	072 KNFT 050	72	90		95	50	35	5	12	7	4		4
075 KNG 055	075 KNF 055	075 KNFT 055	76	95		101	55	40	5	12	7	4		4
080 KNG 060	080 KNF 060	080 KNFT 060	80	105		111	60	40	5	15	7	5		4
085 KNG 065	085 KNF 065	085 KNFT 065	85	110		116	65	45	6	15	8	5		5
090 KNG 065	090 KNF 065	090 KNFT 065	90	115	m6	121	65	45	6	15	8	5		5
095 KNG 070	095 KNF 070	095 KNFT 070	95	120	m6	126	70	50	6	15	8	5		5
100 KNG 075	100 KNF 075	100 KNFT 075	100	130	k6	136	75	50	7	20	9	6		5
105 KNG 080	105 KNF 080	105 KNFT 080	105	135		142	80	55	7	20	9	6		5
110 KNG 080	110 KNF 080	110 KNFT 080	110	140		147	80	55	7	20	9	6		5
120 KNG 090	120 KNF 090	120 KNFT 090	120	155		162	90	60	9	20	10	8		5
125 KNG 095	125 KNF 095	125 KNFT 095	125	160		168	95	65	9	20	12	8		6
130 KNG 100	130 KNF 100	130 KNFT 100	130	170		178	100	70	9	25	12	8		6
140 KNG 105	140 KNF 105	140 KNFT 105	140	180		188	105	75	9	25	14	8		6
150 KNG 115	150 KNF 115	150 KNFT 115	150	195		203	115	80	11	32	15	10	M8	6
160 KNG 120	160 KNF 120	160 KNFT 120	160	205	k6	213	120	86	11	32	15	10	M8	6
170 KNG 130	170 KNF 130	170 KNFT 130	170	220		228	130	90	11	32	15	10	M8	8
180 KNG 135	180 KNF 135	180 KNFT 135	180	230		238	135	96	11	32	18	10	M8	8
190 KNG 145	190 KNF 145	190 KNFT 145	190	245		255	145	100	13	40	18	15	M8	8
200 KNG 150	200 KNF 150	200 KNFT 150	200	260		270	150	105	13	40	20	15	M8	8
210 KNG 160	210 KNF 160	210 KNFT 160	210	270	k6	280	160	110	13	40	20	15	M10	12
225 KNG 170	225 KNF 170	225 KNFT 170	225	290	k6	300	170	120	13	40	20	15	M10	12
235 KNG 175	235 KNF 175	235 KNFT 175	235	305	js6	315	175	120	13	40	20	15	M10	12
250 KNG 190	250 KNF 190	250 KNFT 190	250	325		337	190	130	15.3	50	25	18	M10	15
265 KNG 200	265 KNF 200	265 KNFT 200	265	345		357	200	140	15.3	50	25	18	M10	15
280 KNG 210	280 KNF 210	280 KNFT 210	280	360		372	210	145	15.3	60	28	20	M10	15
300 KNG 225	300 KNF 225	300 KNFT 225	300	390		403	225	155	17.5	60	30	20	M12	15
315 KNG 235	315 KNF 235	315 KNFT 235	315	410		425	235	165	17.5	60	30	20	M12	20
335 KNG 250	335 KNF 250	335 KNFT 250	335	435		451	250	175	17.5	70	35	20	M12	20
355 KNG 265	355 KNF 265	355 KNFT 265	355	460		476	265	185	17.5	70	35	20	M16	20
375 KNG 280	375 KNF 280	375 KNFT 280	375	485	js6	501	280	195	22	70	40	25	M16	20
400 KNG 300	400 KNF 300	400 KNFT 300	400	515		531	300	210	22	85	40	25	M16	20
425 KNG 320	425 KNF 320	425 KNFT 320	425	550		566	320	220	27	85	50	30	M20	25
450 KNG 340	450 KNF 340	450 KNFT 340	450	580		596	340	230	27	110	60	30	M20	25
475 KNG 355	475 KNF 355	475 KNFT 355	475	610		628	355	245	32	110	60	30	M20	25
500 KNG 375	500 KNF 375	500 KNFT 375	500	645	js6	663	375	260	32	110	60	30	M20	25
530 KNG 400	530 KNF 400	530 KNFT 400	530	685		703	400	280	32	110	60	30	M24	30
560 KNG 420	560 KNF 420	560 KNFT 420	560	700		738	420	295	42	120	60	40	M24	30
600 KNG 450	600 KNF 450	600 KNFT 450	600	770		790	450	315	42	120	60	40	M24	30
630 KNG 570	630 KNF 470	630 KNFT 470	630	810		830	470	330	52	150	70	50	M30	35
670 KNG 500	670 KNF 500	670 KNFT 500	670	860	js6	880	500	350	52	150	70	50	M30	35
710 KNG 530	710 KNF 530	710 KNFT 530	710	910	js6	930	530	370	52	150	70	50	M30	40

KN-SERIES

THICK WALL BEARINGS L/D = 1.0

Note: Standard dimensions are shown. Please contact Kingsbury's engineering department for non-standard, make-to-print or English dimensions. Custom L/D ratios are also available on request.

Size Plain bearing in Halves (KNG)	Size Plain bearing in Halves w/ Flanges (KNF)	Size Plain bearing in Halves, Flanges, Loc. Faces (KNFT)	A Bore	B		C	D	E	P	J	K	L	G	U
					Tol									
050 KNG 050	050 KNF 050	050 KNFT 050	50	65		70	50	35	4	10	5	3		4
052 KNG 052	052 KNF 052	052 KNFT 052	52	65		70	52	35	4	10	5	3		4
055 KNG 055	055 KNF 055	055 KNFT 055	55	70		75	55	40	4	10	6	3		4
056 KNG 056	056 KNF 056	056 KNFT 056	56	70		75	56	40	4	10	6	3		4
058 KNG 058	058 KNF 058	058 KNFT 058	58	75	m6	80	58	40	4	10	6	3		4
060 KNG 060	060 KNF 060	060 KNFT 060	60	80		85	60	40	4	10	6	4		4
063 KNG 063	063 KNF 063	063 KNFT 063	63	80		85	63	40	4	10	6	4		4
065 KNG 065	065 KNF 065	065 KNFT 065	65	85		90	65	45	5	12	6	4		4
068 KNG 068	068 KNF 068	068 KNFT 068	68	85		90	68	50	5	12	6	4		4
070 KNG 070	070 KNF 070	070 KNFT 070	70	90	m6	95	70	50	5	12	6	4		4
072 KNG 072	072 KNF 070	072 KNFT 072	72	90		95	72	50	5	12	7	4		4
075 KNG 075	075 KNF 075	075 KNFT 075	76	95		101	75	50	5	12	7	4		4
080 KNG 080	080 KNF 080	080 KNFT 080	80	105		111	80	55	5	15	7	5		4
085 KNG 085	085 KNF 085	085 KNFT 085	85	110		116	85	60	6	15	8	5		5
090 KNG 090	090 KNF 090	090 KNFT 090	90	115	m6	121	90	65	6	15	8	5		5
095 KNG 095	095 KNF 095	095 KNFT 095	95	120	m6	126	95	65	6	15	8	5		5
100 KNG 100	100 KNF 100	100 KNFT 100	100	130	k6	136	100	70	7	20	9	6		5
105 KNG 105	105 KNF 105	105 KNFT 105	105	135		142	105	75	7	20	9	6		5
110 KNG 110	110 KNF 110	110 KNFT 110	110	140		147	110	75	7	20	9	6		5
120 KNG 120	120 KNF 120	120 KNFT 120	120	155		162	120	85	9	20	10	8		5
125 KNG 125	125 KNF 125	125 KNFT 125	125	160		168	125	90	9	20	12	8		6
130 KNG 130	130 KNF 130	130 KNFT 130	130	170		178	130	90	9	25	12	8		6
140 KNG 140	140 KNF 140	140 KNFT 140	140	180		188	140	100	9	25	14	8		6
150 KNG 150	150 KNF 150	150 KNFT 150	150	195		203	150	105	11	32	15	10	M8	6
160 KNG 160	160 KNF 160	160 KNFT 160	160	205	k6	213	160	110	11	32	15	10	M8	6
170 KNG 170	170 KNF 170	170 KNFT 170	170	220		228	170	120	11	32	15	10	M8	8
180 KNG 180	180 KNF 180	180 KNFT 180	180	230		238	180	125	11	32	18	10	M8	8
190 KNG 190	190 KNF 190	190 KNFT 190	190	245		255	190	135	13	40	18	15	M8	8
200 KNG 200	200 KNF 200	200 KNFT 200	200	260		270	200	140	13	40	20	15	M8	8
210 KNG 210	210 KNF 210	210 KNFT 210	210	270	k6	280	210	145	13	40	20	15	M10	12
225 KNG 225	225 KNF 225	225 KNFT 225	225	290	k6	300	225	160	13	40	20	15	M10	12
235 KNG 235	235 KNF 235	235 KNFT 235	235	305	j _s 6	315	235	165	13	40	20	15	M10	12
250 KNG 250	250 KNF 250	250 KNFT 250	250	325		337	250	175	15.3	50	25	18	M10	15
265 KNG 265	265 KNF 265	265 KNFT 265	265	345		357	265	185	15.3	50	25	18	M10	15
280 KNG 280	280 KNF 280	280 KNFT 280	280	360		372	280	195	15.3	60	28	20	M10	15
300 KNG 300	300 KNF 300	300 KNFT 300	300	390		403	300	210	17.5	60	30	20	M12	15
315 KNG 315	315 KNF 315	315 KNFT 315	315	410		425	315	220	17.5	60	30	20	M12	20
335 KNG 335	335 KNF 335	335 KNFT 335	335	435		451	335	235	17.5	70	35	20	M12	20
355 KNG 355	355 KNF 355	355 KNFT 355	355	460		476	355	250	17.5	70	35	20	M16	20
375 KNG 375	375 KNF 375	375 KNFT 375	375	485	j _s 6	501	375	260	22	70	40	25	M16	20
400 KNG 400	400 KNF 400	400 KNFT 400	400	515		531	400	280	22	85	40	25	M16	20
425 KNG 425	425 KNF 425	425 KNFT 425	425	550		566	425	300	27	85	50	30	M20	25
450 KNG 450	450 KNF 450	450 KNFT 450	450	580		596	450	320	27	110	60	30	M20	25
475 KNG 475	475 KNF 475	475 KNFT 475	475	610		628	475	330	32	110	60	30	M20	25
500 KNG 500	500 KNF 500	500 KNFT 500	500	645	j _s 6	663	500	350	32	110	60	30	M20	25
530 KNG 530	530 KNF 530	530 KNFT 530	530	685		703	530	370	32	110	60	30	M24	30
560 KNG 560	560 KNF 560	560 KNFT 560	560	700		738	560	390	42	120	60	40	M24	30
600 KNG 600	600 KNF 600	600 KNFT 600	600	770		790	600	420	42	120	60	40	M24	30
630 KNG 630	630 KNF 630	630 KNFT 630	630	810		830	630	440	52	150	70	50	M30	35
670 KNG 670	670 KNF 670	670 KNFT 670	670	860	j _s 6	880	670	470	52	150	70	50	M30	35
710 KNG 710	710 KNF 710	710 KNFT 710	710	910	j _s 6	930	710	500	52	150	70	50	M30	40



The Best Support In The Business.®

10385 Drummond Road
Philadelphia, PA 19154 USA
Telephone: 1-215-824-4000
Fax: 1-215-824-4999
www.kingsbury.com